

Service Manual

COLOR TELEVISION

CHASSIS : CN-794N

**Model : DTQ-29U1SC/SSP
DTQ-29U5SC/SSP**



DTQ-29U1SC



DTQ-29U1SC

Caution

: In this Manual, some parts can be changed for improving their performance without notice in the parts list. So, if you need the latest parts information, please refer to PPL(Parts Price List)in Service Information Center(<http://svc.dwe.co.kr>)

TABLE OF CONTENTS

SAFETY PRECAUTIONS	2
SPECIFICATIONS	5
CIRCUIT BLOCK DIAGRAM	6
ALIGNMENT INSTRUCTIONS	7
YOUR REMOTE CONTROL	7
SERVICE MODE ADJUSTMENT	8
ASSEMBLY ADJUSTMENT	10
SCHEMATIC DIAGRAM	13
ELECTRICAL PARTS LIST	17
DIFFERENT PARTS LIST	36
EXPLODE VIEW	37
PRINTED CIRCUIT BOARD	39

APPENDIX(Appendix is provide only by internet[<http://svc.dwe.co.kr>])

IC DESCRIPTION	49
WAVEFORMS	55
TROUBLE SHOOTING GUIDE	58
NO POWER	58
NO PICTURE	59
NO SOUND	60
CH DON T STOP	61
NO COLOR	62
NO VERTICAL DEFLECTION	62
NO ON-SCREEN DISPLAY	63
NO REMOCON RECEIPT	63

SAFETY PRECAUTIONS

CAUTION : DO NOT ATTEMPT TO MODIFY THIS PRODUCT IN ANY WAY. NEVER PERFORM CUSTOMIZED INSTALLATIONS WITHOUT MANUFACTURER'S APPROVAL. UNAUTHORIZED MODIFICATIONS WILL NOT ONLY VOID THE WARRANTY, BUT MAY LEAD TO YOUR BEING LIABLE FOR ANY RESULTING PROPERTY DAMAGE OR USER INJURY.

SERVICE WORK SHOULD BE PERFORMED ONLY AFTER YOU ARE THOROUGHLY FAMILIAR WITH ALL OF THE FOLLOWING SAFETY CHECKS AND SERVICING GUIDELINES. TO DO OTHERWISE, INCREASES THE RISK OF POTENTIAL HAZARDS AND INJURY TO THE USER.

WHILE SERVICING, USE AN ISOLATION TRANSFORMER FOR PROTECTION FROM A.C. LINE SHOCK.

SAFETY CHECKS

AFTER THE ORIGINAL SERVICE PROBLEM HAS BEEN CORRECTED, A CHECK SHOULD BE MADE OF THE FOLLOWING:

SUBJECT: FIRE & SHOCK HAZARD

1. BE SURE THAT ALL COMPONENTS ARE POSITIONED IN SUCH A WAY AS TO AVOID POSSIBILITY OF ADJACENT COMPONENT SHORTS. THIS IS ESPECIALLY IMPORTANT ON THOSE MODULES WHICH ARE TRANSPORTED TO AND FROM THE REPAIR SHOP.
2. NEVER RELEASE A REPAIR UNLESS ALL PROTECTIVE DEVICES SUCH AS INSULATORS, BARRIERS, COVERS, SHIELDS, STRAIN RELIEFS, POWER SUPPLY CORDS, AND OTHER HARDWARE HAVE BEEN REINSTALLED PER ORIGINAL DESIGN. BE SURE, THAT THE SAFETY PURPOSE OF THE POLARIZED LINE PLUG HAS NOT BEEN DEFEATED.
3. SOLDERING MUST BE INSPECTED TO DISCOVER POSSIBLE COLD SOLDER JOINTS, SOLDER SPLASHES OF SHARP SOLDER POINTS. BE CERTAIN TO REMOVE ALL LOOSE FOREIGN PARTICLES.
4. CHECK FOR PHYSICAL EVIDENCE OF DAMAGE OR DETERIORATION TO PARTS AND COMPONENTS, FOR FRAYED LEADS, DAMAGED INSULATION (INCLUDING A.C. CORD), AND REPLACE IF NECESSARY. FOLLOW ORIGINAL LAYOUT, LEAD LENGTH AND DRESS.
5. NO LEAD OR COMPONENT SHOULD TOUCH A RECEIVING TUBE OR A RESISTOR RATED AT 1 WATT OR MORE. LEAD TENSION AROUND PROTRUDING METAL SURFACES MUST BE AVOIDED.
6. ALL CRITICAL COMPONENTS SUCH AS FUSES, FLAMEPROOF RESISTOR, CAPACITORS, ETC. MUST BE REPLACED WITH EXACT FACTORY TYPES. DO NOT USE REPLACEMENT COMPONENTS OTHER THAN THOSE SPECIFIED OR MAKE UNRECOMMENDED CIRCUIT MODIFICATIONS.
7. AFTER RE-ASSEMBLY OF THE SET ALWAYS PERFORM AN A.C. LEAKAGE TEST ON ALL EXPOSED METALLIC PARTS OF THE CABINET. (THE CHANNEL SELECTOR KNOB, ANTENNA TERMINALS, HANDLE AND SCREWS) TO BE SURE THE SET IS SAFE TO OPERATE WITHOUT DANGER OF ELECTRICAL SHOCK. DO NOT USE A LINE ISOLATION TRANSFORMER DURING THIS TEST USE AN A.C. VOLTMETER, HAVING 5000 OHMS PER VOLT OR MORE SENSITIVITY, IN THE FOLLOWING MANNER : CONNECT A 1500 OHM 10 WATT RESISTOR, PARALLELED BY A .15 MFD. 150V A.C. TYPE CAPACITOR BETWEEN A KNOWN GOOD EARTH GROUND (WATER PIPE, CONDUIT, ETC.) AND THE EXPOSED METALLIC PARTS, ONE AT A TIME. MEASURE THE A.C. VOLTAGE ACROSS THE COMBINATION OF 1500 OHM RESISTOR AND .15 MFD CAPACITOR. REVERSE THE A.C. PLUG AND REPEAT A.C. VOLTAGE MEASUREMENTS FOR EACH EXPOSED METALLIC PART. VOLTAGE MEASURED MUST NOT EXCEED .75 VOLTS R.M.S THIS CORRESPONDS TO 0.5 MILLIAMPS A.C. ANY VALUE EXCEEDING THIS LIMIT CONSTITUTES A POTENTIAL SHOCK HAZARD AND MUST BE CORRECTED IMMEDIATELY.

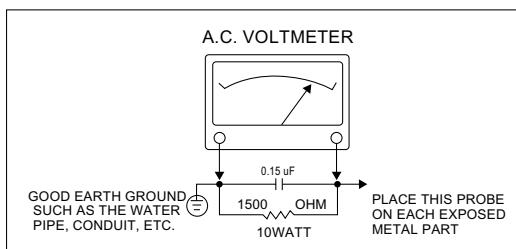

SUBJECT : GRAPHIC SYMBOLS



THE LIGHTNING FLASH WITH ARROWHEAD SYMBOL, WITHIN AN EQUILATERAL TRIANGLE, IS INTENDED TO ALERT THE SERVICE PERSONNEL TO THE PRESENCE OF UNINSULATED DANGEROUS VOLTAGE THAT MAY BE OF SUFFICIENT MAGNITUDE TO CONSTITUTE A RISK OF ELECTRIC SHOCK.



THE EXCLAMATION POINT WITHIN AN EQUILATERAL TRIANGLE IS INTENDED TO ALERT THE SERVICE PERSONNEL TO THE PRESENCE OF IMPORTANT SAFETY INFORMATION ON SERVICE LITERATURE.

SUBJECT : X-RADIATION

1. BE SURE PROCEDURES AND INSTRUCTIONS TO ALL SERVICE PERSONNEL COVER THE SUBJECT OF X-RADIATION. THE ONLY POTENTIAL SOURCE OF X-RAYS IN CURRENT T.V. RECEIVERS IS THE PICTURE TUBE. HOWEVER, THIS TUBE DOES NOT EMIT X-RAYS WHEN THE HIGH VOLTAGE IS AT THE FACTORY SPECIFIED LEVEL. THE PROPER VALUE IS GIVEN IN THE APPLICABLE SCHEMATIC. OPERATION AT HIGHER VOLTAGES MAY CAUSE A FAILURE OF THE PICTURE TUBE OR HIGH VOLTAGE SUPPLY AND UNDER CERTAIN CIRCUMSTANCES, MAY PRODUCE RADIATION IN EXCESS OF DESIRABLE LEVELS.
2. ONLY FACTORY SPECIFIED C.R.T ANODE CONNECTORS MUST BE USED. DEGAUSSING SHIELDS ALSO SERVE AS X-RAY SHIELD IN COLOR SETS. ALWAYS RE-INSTALL THEM.
3. IT IS ESSENTIAL THAT SERVICE PERSONNEL HAVE AVAILABLE AN ACCURATE AND RELIABLE HIGH VOLTAGE METER. THE CALIBRATION OF THE METER SHOULD BE CHECKED PERIODICALLY AGAINST A REFERENCE STANDARD. SUCH AS THE ONE AVAILABLE AT YOUR DISTRIBUTOR.
4. WHEN THE HIGH VOLTAGE CIRCUITRY IS OPERATING PROPERLY THERE IS NO POSSIBILITY OF AN X-RADIATION PROBLEM. EVERY TIME A COLOR CHASSIS IS SERVICED, THE BRIGHTNESS SHOULD BE RUN UP AND DOWN WHILE MONITORING THE HIGH VOLTAGE WITH A METER TO BE CERTAIN THAT THE HIGH VOLTAGE DOES NOT EXCEED THE SPECIFIED VALUE AND THAT IT IS REGULATING CORRECTLY. WE SUGGEST THAT YOU AND YOUR SERVICE ORGANIZATION REVIEW TEST PROCEDURES SO THAT VOLTAGE REGULATION IS ALWAYS CHECKED AS A STANDARD SERVICING PROCEDURE, AND THAT THE HIGH VOLTAGE READING BE RECORDED ON EACH CUSTOMER'S INVOICE.
5. WHEN TROUBLESHOOTING AND MAKING TEST MEASUREMENTS IN A PRODUCT WITH A PROBLEM OF EXCESSIVE HIGH VOLTAGE, AVOID BEING UNNECESSARILY CLOSE TO THE PICTURE TUBE AND THE HIGH VOLTAGE SUPPLY. DO NOT OPERATE THE PRODUCT LONGER THAN IS NECESSARY TO LOCATE THE CAUSE OF EXCESSIVE VOLTAGE.
6. REFER TO HV, B+ AND SHUTDOWN ADJUSTMENT PROCEDURES DESCRIBED IN THE APPROPRIATE SCHEMATIC AND DIAGRAMS (WHERE USED).

SUBJECT : IMPLOSION

1. ALL DIRECT VIEWED PICTURE TUBES ARE EQUIPPED WITH AN INTEGRAL IMPLOSION PROTECTION SYSTEM. BUT CARE SHOULD BE TAKEN TO AVOID DAMAGE DURING INSTALLATION. AVOID SCRATCHING THE TUBE. OF SCRATCHED REPLACE IT.
2. USE ONLY RECOMMENDED FACTORY REPLACEMENT TUBES.

SUBJECT : TIPS ON PROPER INSTALLATION

1. NEVER INSTALL ANY PRODUCT IN A CLOSED-IN RECESS, CUBBYHOLE OR CLOSELY FITTING SHELF SPACE, OVER OR CLOSE TO HEAT DUCT, OR IN THE PATH OF HEATED AIR FLOW.
2. AVOID CONDITIONS OF HIGH HUMIDITY SUCH AS: OUTDOOR PATIO INSTALLATIONS WHERE DEW IS A FACTOR, NEAR STEAM RADIATORS WHERE STEAM LEAKAGE IS A FACTOR, ETC.
3. AVOID PLACEMENT WHERE DRAPERIES MAY OBSTRUCT REAR VENTING. THE CUSTOMER SHOULD ALSO AVOID THE USE OF DECORATIVE SCARVES OR OTHER COVERINGS WHICH MIGHT OBSTRUCT VENTILATION.
4. WALL AND SHELF MOUNTED INSTALLATIONS USING A COMMERCIAL MOUNTING KIT, MUST FOLLOW THE FACTORY APPROVED MOUNTING INSTRUCTIONS. A PRODUCT MOUNTED TO A SHELF OR PLATFORM MUST RETAIN ITS ORIGINAL FEET (OR THE EQUIVALENT THICKNESS IN SPACERS) TO PROVIDE ADEQUATE AIR FLOW ACROSS THE BOTTOM, BOLTS OR SCREWS USED FOR FASTENERS MUST NOT TOUCH ANY PARTS OR WIRING. PERFORM LEAKAGE TEST ON CUSTOMIZED INSTALLATIONS.
5. CAUTION CUSTOMERS AGAINST THE MOUNTING OF A PRODUCT ON SLOPING SHELF OR A TILTED POSITION, UNLESS THE PRODUCT IS PROPERLY SECURED.
6. A PRODUCT ON A ROLL-ABOUT CART SHOULD BE STABLE ON ITS MOUNTING TO THE CART. CAUTION THE CUSTOMER ON THE HAZARDS OF TRYING TO ROLL A CART WITH SMALL CASTERS ACROSS THRESHOLDS OR DEEP PILE CARPETS.
7. CAUTION CUSTOMERS AGAINST THE USE OF A CART OR STAND WHICH HAS NOT BEEN LISTED BY UNDERWRITERS LABORATORIES, INC. FOR USE WITH THEIR SPECIFIC MODEL OF TELEVISION RECEIVER OR GENERALLY APPROVED FOR USE WITH T.V.S OF THE SAME OR LARGER SCREEN SIZE.
8. CAUTION CUSTOMERS AGAINST THE USE OF EXTENSION CORDS, EXPLAIN THAT A FOREST OF EXTENSIONS SPROUTING FROM A SINGLE OUTLET CAN LEAD TO DISASTROUS CONSEQUENCES TO HOME AND FAMILY.

SAFETY PRECAUTIONS

CAUTION : Do not attempt to modify this product in any way. Unauthorized modifications will not only void the warranty, but may lead to your being liable for any resulting property damage or user injury.

Service work should be performed only after you are thoroughly familiar with all of the following safety checks and servicing guide-lines. To do otherwise, increases the risk of potential hazards and injury to the user.

SAFETY CHECKS

After the original service problem has been corrected, a check should be made of the following:

SUBJECT : FIRE & SHOCK HAZARD

1. Be sure that all components are positioned in such a way as to avoid possibility of adjacent component shorts. This is especially important on those chassis which are transported to and from the repair shop.
2. Never release a repair unless all protective devices such as insulators, barriers, covers, shields, strain reliefs, and other hardware have been reinstalled per original design.
3. Soldering must be inspected to discover possible cold solder joints, frayed leads, damaged insulation (including A.C. cord), solder splashes or sharp solder points. Be certain to remove all loose foreign particles.
4. Check for physical evidence of damage or deterioration to parts and components, and replace if necessary follow original layout, lead length and dress.
5. No leads or components should touch a receiving tube or a resistor rated at 1 watt or more. Lead tension around protruding metal surfaces must be avoided.
6. All critical components such as fuses, flameproof resistors, capacitors, etc. must be replaced with exact factory types. Do not use replacement components other than those specified or make unrecommended circuit modifications.
7. After re-assembly of the set always perform an A.C. leakage test on all exposed metallic parts of the cabinet, (the channel selector knob, antenna terminals, handle and screws) to be sure the set is safe to operate without danger of electrical shock. Do not use a line isolation transformer during this test. Use an A.C. voltmeter, having 5000 ohms per volt or more sensitivity, in the following manner : connect a 1500 ohm 10 watt resistor, paralleled by a 15 mfd. 150V A.C. type capacitor between a known good earth ground (water pipe, conduit, etc.) and the exposed metallic parts, one at a time. Measure the A.C. voltage across the combination of 1500 ohm resistor and 0.15 MFD capacitor. Reverse the A.C. plug and repeat A.C. voltage measurements for each exposed metallic part. Voltage measured must not exceed 0.75 volts R.M.S. This corresponds to 0.5 milliamp A.C. Any value exceeding this limit constitutes a potential shock hazard and must be corrected immediately.

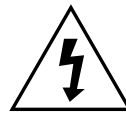
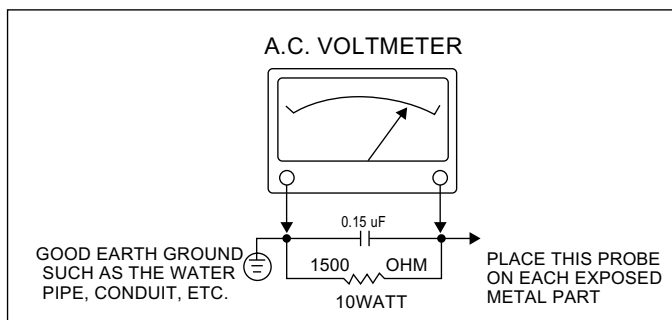

The lightning flash with arrowhead symbol, within an equilateral triangle, is intended to alert the service personnel to the presence of uninsulated dangerous voltage that may be of sufficiently magnitude to constitute a risk of electric shock.



The exclamation point within an equilateral triangle is intended to alert the service personnel to the presence of important safety information in service literature.

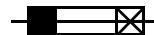

Fuse symbol is printed on pcb adjacent to the fuse, with RISK OF FIRE REPLACE FUSE AS MARKED . The symbol is explained in the service manual with the following wording or equivalent.

CAUTION : FOR CONTINUED PROTECTION AGAINST FIRE HAZARD, REPLACE ONLY WITH SAME TYPE (4A, 125V) and **ATTENTION**: AFIN D ASSU UNE PROTECTION PERMANENTE CONTRE LES RISQUES D INCENDIE, REMPLACER UNIQUEMENT PAR UN FUSIBLE DE MEME TYPE ET DE 4A, 125V .

SUBJECT : X-RADIATION

1. Be sure procedures and instructions to all service personnel cover the subject of X-rays in current T.V. receivers is the picture tube. However, this tube does not emit X-rays when the high voltage is at the factory specified level. The proper value is given in the applicable schematic. Operation at higher voltages may cause a failure of the picture tube or high voltage supply and, under certain circumstances, may produce radiation in excess of desirable levels.
2. Only factory specified C.R.T. anode connectors must be used. Degaussing shields also serve as X-ray shield in color sets. Always re-install them.
3. It is essential that the serviceman has available an accurate and reliable high voltage meter. The calibration of the meter should be checked periodically against a reference standard. Such as the one available at your distributor.
4. When the high voltage circuitry is operating properly there is no possibility of an X-radiation problem. Every time a color chassis is serviced, the brightness should be run up and down while monitoring the high voltage with a meter to be certain that the high voltage does not exceed the specified value and that it is regulating correctly. We suggest that you and your service organization review test procedures so that voltage regulation is always checked as a standard servicing procedure. And that the high voltage reading be recorded on each customer's invoice.
5. When troubleshooting and making test measurements in a receiver with a problem of excessive high voltage, avoid being unnecessarily close to the picture tube and the high voltage compartment. Do not operate the chassis longer than is necessary to locate the cause of excessive voltage.
6. Refer to HV, B+ and Shutdown adjustment procedures described in the appropriate schematic and diagrams (where used).

SAFETY PRECAUTIONS

SUBJECT : IMPLOSION

1. All direct viewed picture tubes are equipped with an integral implosion protection system, but care should be taken to avoid damage during installation. Avoid scratching the tube. If scratched, replace it.
2. Use only recommended factory replacement tubes.

SUBJECT : TIPS ON PROPER INSTALLATION

1. Never install any receiver in closed-in recess, cubbyhole or closely fitting shelf space over, or close to heat duct, or in the path of heated air flow.
2. Avoid conditions of high humidity such as : Outdoor patio installations where dew is a factor. Near steam radiators where steam leakage is a factor, etc.
3. Avoid placement where draperies may obstruct rear venting. The customer should also avoid the use of decorative scarves or other coverings which might obstruct ventilation.
4. Wall and shelf mounted installations using a commercial mounting kit, must follow the factory approved mounting instructions. A receiver mounted to a shelf or platform must retain its original feet(or the equivalent thickness in spacers) to provide adequate air flow across the bottom, bolts or screws used for fasteners must not touch and parts or wiring. Perform leakage test on customized installations.
5. Caution customers against the mounting of a receiver on sloping shelf or a tilted position, unless the receiver is properly secured.
6. A receiver on a roll-about cart should be stable on its mounting to the cart. Caution the customer on the hazards of trying to roll a cart with small casters across thresholds or deep pile carpets.
7. Caution customers against the use of a cart or stand which has not been listed by underwriters laboratories, inc. For use with their specific model of television receiver or generically approved for use with T.V. s of the same or larger screen size.

SPECIFICATION

Item	Model	DTQ-29U1/U5SC	DTQ-29U1/U5SSP
CHASSIS		CN-794N	
TV Standard		NTSC-M	
Power Input		AC 120v, 60Hz	
Power Consumption		112W	
Tuning System		Frequency Synthesizer(FS) Tuning System	
Tuning Ranges		TV VHF(L) : CH2 - CH6 UHF(H) : CH7 - CH13 UHF : CH14 - CH69 CATV VHF(L) : 5A, A,B,A-5-A-1 CH2-CH6 VHF(H) : C-W+11 CH7 - CH13 UHF : W+12-W+84”	
Sound Output		5W + 5W	7W + 7W
Speaker		8 ohm 7W x 2EA	8 ohm 15W x 2EA
Antenna Input Impedance		75 ohm Unbalanced	
Auxiliary Input Terminal		Side : Video, Audio(L,R) - AV2 Rear : Video, Audio(L,R) - AV1 S-Video Y, Cb, Cr, Audio(L,R) - CVI	
Auxiliary Output Terminal		Rear : Video, Audio(L,R) - MONITOR OUT	
Intermediate Frequencies		Picture IF Carrier Frequency : 45.75MHz Sound IF Carrier Frequency : 41.25MHz Color Sub-Carrier Frequency : 3.579545MHz	
Remote Control		R-43A07	
Special Function		1) Closed Caption 2) V-Chip 3) Channel Label	

CIRCUIT BLOCK DIAGRAM

CN-794N STEREO MODEL for US (with Component Input)

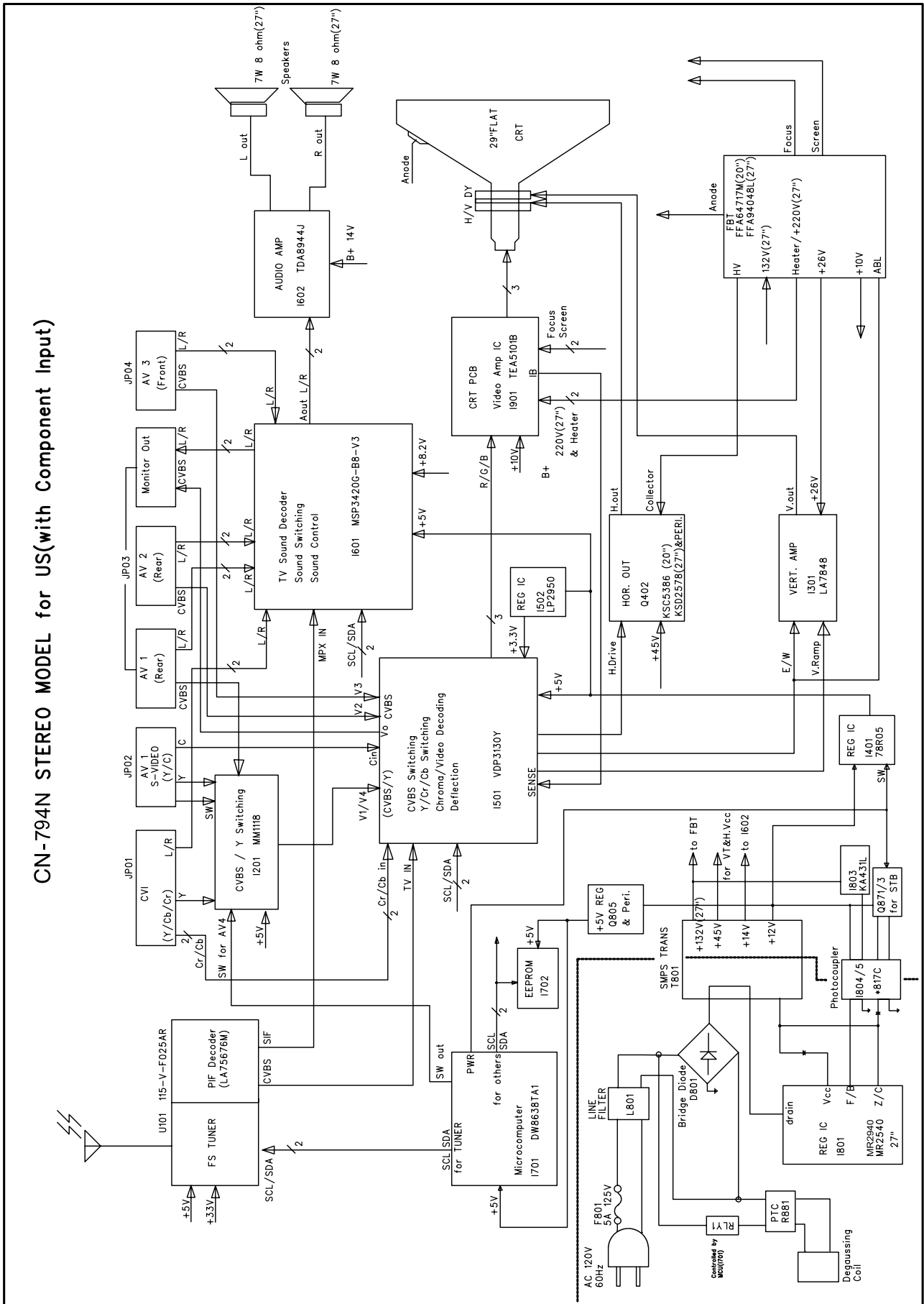

ALIGNMENT INSTRUCTION

Your Remote Control (6143A07)

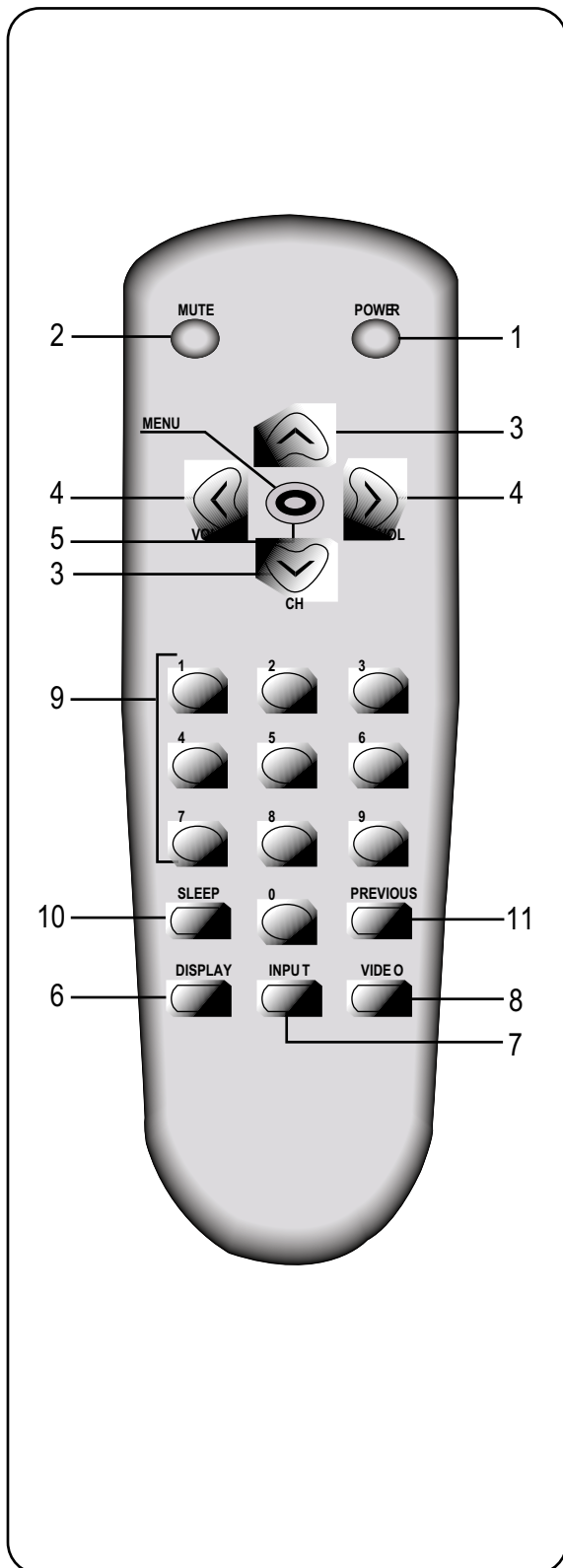

- 1. POWER**
use this button to turn your TV on or off.
- 2. MUTE**
Use to turn the TV's sound on and off.
- 3. ▼CH▲**
Use these buttons to change your TV's volume, to activate selections in the menu system.
- 4. ◀VOL▶**
Use these buttons to change your TV's volume, to activate selections in the menu system, or to change audio and video settings.
- 5. MENU**
Use this button to turn the TV's menu system on and off.
- 6. DISPLAY**
Use this button to display the channel number and status.
- 7. INPUT**
Use this button to select the TV's signal source.
- 8. VIDEO**
Use this button to display video adjustment.
- 9. 0-9**
Use these buttons to change channels.
- 10. SLEEP**
Use this button to program the TV to turn off after a certain time.
- 11. PREVIOUS**
Use this button to return to the previous channel you were watching.

ALIGNMENT INSTRUCTION

1. SERVICE MODE ADJUSTMENTS

Follow the steps below whenever service adjustment is required. See Table- A and Table- B to determine if service adjustments are required.

1) How to enter the service mode using the user remote control.

- Turn the set on.
- Direct the remote control to the reception window of TV.
- Push buttons of remote control in sequence as follows.

1 → MUTE → DISPLAY → MUTE

- Then, the screen will appear as follows.

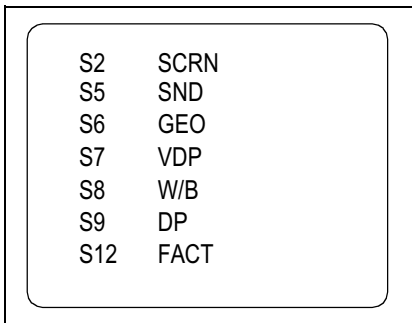

- Using the channel up or channel down button, select the item you wish to adjust.
(The color of selected item turns into the red.)
- Press the volume up or down button to enter in the service mode you wish to adjust.

2) How to memorize the adjusted values in the service mode.

- Must press **DISPLAY** button the state which the screen is displaying each of service menus after all adjustments are completed each of all service menu.

Table-A : Adjust the values of service mode when a part is replaced.

PART REPLACED	ADJUSTMENT		NOTES
	NECESSARY	UNNECESSARY	
I701 (U-COM)		○	Data is stored in I703.
I101 (MAIN)		○	
I703 (EEPROM)	○		Initial setting values are written from I701. ADJUSTING ITEMS S5 : SOUND CONTROL S6 : H.PHASE/H.SIZE/V.POSI/V.SIZE S8 : RD/GD/BD/RB/GB/BB S9 Subbrightness
CRT	○		Adjust items related to picture tube only.(White Balance adjustment)

ALIGNMENT INSTRUCTION

Table-B

MODE	ADJUSTMENT	DATA		RANGE	REMARKS	
		OEC	LG			
S2	Screen Adjustment					
S5	SOUND CONTROL					
	FM/AM PRE	65(SSP:75)		0~127		
	SCART PRE	65(SSP:70)		0~127		
	MONI VOL	32(SSP:20)		0~127		
	QUASI CHECK	NO		YES/NO		
	NO SD NO POWER	NO		YES/NO		
S6	V-SIZE	399	379	0~510		
	V-POSI	1104	1168	240~1712		
	H-PHASE	41	36	0~255		
	H-SIZE	1156	1060	4~4092		
	V-LIN	271	269	0~511		
	V-S		237	2~512		
	HBST		20	0~511		
	TILT		504	8~1016		
	P-PARA		549	3~1021		
	H-SYM		984	8~2040		
	H-COR		984	8~2040		
	HBSO		6	0~511		
	S7	BCLTH		185	0~2047	
		BCLTM		5	0~15	
BCLG			5	0~15		
BCLTST			0	0~1020		
PKINV			0	0/1		
BLE			0	0/1		
BTLT			2	0~15		
BAM			20	0~31		
SVG1			20	0~63		
SVD1			1	0~7		
SVLIM			30	0~127		
SVDEL			7	0~15		
OSDBR			255	0~511		
OSDCO			120	0~511		
S8-1		RD		700	0~1023	
		GD		700	0~1023	
		BD		700	0~1023	
	RB		350	0~511		
	GB		350	0~511		
	BB		350	0~511		
S8-2	SCR R-BIAS		0	0~511		
	SCR G-BIAS		0	0~511		
	SCR B-BIAS		420	0~511		
	SCR R-DRIVE		0	0~1023		
	SCR G-DRIVE		0	0~1023		
	SCR B-DRIVE		200	0~1023		
S9	DP-BRI		145	0~310		
	DP-CONT		13	0~13		
	DP-TINT		170	0~222		
	DP-COL		200	0~850		
	DP-OVPK		4	0~4		
	DP-UNPK		2	0~4		
	BRI-SET		75	0~100		
S11	DVCO		OK			
S12	Forwarding Mode				Factory initialization	

ALIGNMENT INSTRUCTION

2. ASSEMBLY ADJUSTMENTS

1) SCREEN ADJUSTMENT (S2)

- Enter the service mode and select service adjustment S2.
- You can see the one horizontal line on the screen.
- Adjust the Screen Control Volume (located on FBT) so that the horizontal line onscreen may be disappeared.
- Press the volume up or down button to exit in the screen adjustment mode.

CAUTION

IN THE SCREEN ADJUSTMENT MODE, DONT PRESS OTHER BUTTONS EXCEPT VOLUME UP OR DOWN BUTTON.

2) FOCUS ADJUSTMENT

- Turn in a local station and adjust the Focus Control knob (located on FBT) for best picture details at high light condition.

3) GEOMETRIC ADJUSTMENTS (S6)

- Select service adjustment S6
- You can see the OSD as shown in below.

V-SIZE	379	TILT	504
V-POSI	1168	P-PARA	549
H-PHASE	36	H-SYM	984
H-SIZE	1060	H-COR	984
V-LIN	269	HBSO	358
V-S	237		
HBST	260		

3-1. Horizontal Position Adjustment

- Select H-PHASE item, adjust H-PHASE data value to obtain proper horizontal centering of the internal cross pattern at the left and right of the screen.

3-2. Vertical Position Adjustment

- Select V-POSI item, adjust V-POSI data value to center the raster properly on the screen.

3-3. Vertical Size Adjustment

- Select "V.SIZE" item, adjust "V.SIZE" data value to proper vertical size as follows.

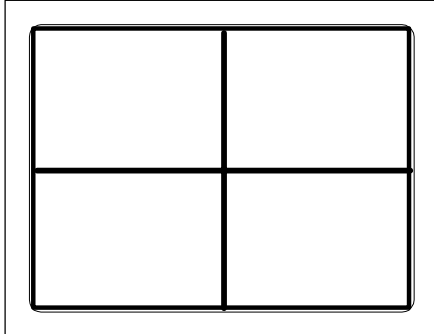

4) WHITE BALANCE ADJUSTMENT(S8)

- Receive a good local channel.
- Enter the service mode and select service adjustment S8.
- You can see the OSD as shown in below.

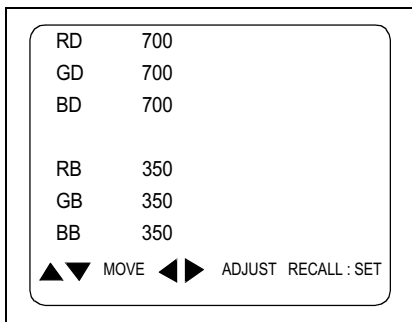

- Using volume up or volume down, adjust service adjustment data of RD/GD/BD and RB/GB/BB until a good gray scale with normal whites is obtained.
- Press the DISPLAY button to memorize the data.

5) DIGITAL PRESET(D.P) ADJUSTMENTS(S9)

SUBBRIGHTNESS ADJUSTMENT

- Receive a good local channel.
- Enter the service mode and select service adjustment S9.
- You can see the OSD as shown in below.

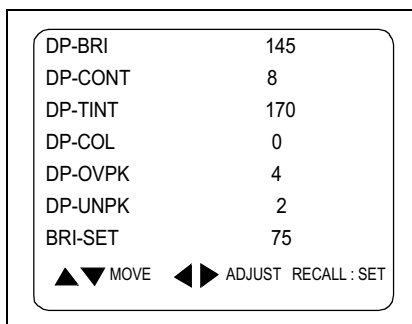

ALIGNMENT INSTRUCTION

- Select Subbrightness item, adjust Subbrightness data value to obtain normal brightness level.
- Press the DISPLAY button to memorize the data.

CONTRAST

- Fixed value = 8

TINT

- Fixed value = 170

COLOR

- Fixed value = 0

6) FACTORY OUTGOING MODE (S12 : FACT)

- If you select the S12, then the set becomes factory outgoing status.
- You can see the OSD "outgoing OK"

ELECTRICAL PARTS LIST

★Caution

: In this Manual, some parts can be changed for improving. their performance without notice in the parts list. So, if you need the latest parts information, please refer to PPL(Parts Price List)in Service Information Center(<http://svc.dwe.co.kr>)

**This BOM is based on DTQ-29U1SC

NO	LOC	PARTS CODE	PARTS NAME	PARTS DESCRIPTION	REMARK
1	ZZ100	48B4343A07	TRANSMITTER REMOCON	R-43A07 (AA)	Ⓜ
2	ZZ110	PTACPWJ954	ACCESSORY AS	DTQ-21U4SC	
3	M821	4858213801	BAG INSTRUCTION	L.D.PE T0.05X250X400	
4	ZZ120	PTBCSHK016	COVER BACK AS	DTQ-29U1SC	
5	M211	4852163100	COVER BACK	FR HIPS GY 29U1	
6	M781	4857817630	CLOTH BLACK	FELT 400X20X0.7	
7	M782	4857817612	CLOTH BLACK	FELT 250X20X0.7	
8	ZZ130	PTPKCPK016	PACKING AS	DTQ-29U1SC	
9	10	6520010100	STAPLE PIN	AUTO W65	
10	M681	4856812400	BAND PP AUTO	T1.1XW17mmXL770M	
11	M801	4858057600	BOX CARTON	DW-3	
12	M811	4858101100	PAD	EPS 29U1	
13	M821	4858215601	BAG P.E	PE FOAM t0.5x1600x1270	
14	ZZ131	48519A4210	CRT GROUND NET	2901H-1015-2P	
15	ZZ132	58G0000143	COIL DEGAUSSING	DC-29S1	⚠
16	ZZ140	PTCACAK016	CABINET AS	DTQ-29U1SC	
17	M111A	7172401612	SCREW TAPPTITE	TT2 TRS 4X16 MFZN BK	
18	M201A	4856015821	SCREW CRT FIX	SWRM+SK5 L=35	
19	M201C	4856215404	WASHER RUBBER	CR T4.0	
20	M201E	4856816300	CLAMP WIRE	NYLON 6 (V0)	
21	M211A	7172401612	SCREW TAPPTITE	TT2 TRS 4X16 MFZN BK	
22	M211B	7172401612	SCREW TAPPTITE	TT2 TRS 4X16 MFZN BK	
23	M221C	7178301212	SCREW TAPPTITE	TT2 WAS 3X12 MFZN BK	
24	M541	4855415800	SPEC PLATE	150ART P/E FILM (C/TV)	
25	M686	4856812001	TIE CABLE	NYLON66 DA100	
26	SP01A	7172401212	SCREW TAPPTITE	TT2 TRS 4X12 MFZNBK	
27	SP01B	7172401212	SCREW TAPPTITE	TT2 TRS 4X12 MFZNBK	
28	V901	4859639260	CRT	A68QCU757X81 P38	⚠
29	ZZ200	PTFMSJK016	MASK FRONT AS	DTQ-29U1SC	
30	M191	4851948400	BUTTON CTRL	4955100+5549200 29U1	
31	M191A	7178301011	SCREW TAPPTITE	TT2 WAS 3X10 MFZN	
32	M201	4852083500	MASK FRONT	FR HIPS GY 29U1	
33	M481	4854864100	BUTTON POWER	FR HIPS GY 29U1	
34	M481A	4856716000	SPRING	SWPA PIE0.5	
35	M561	4855617400	MARK BRAND	CU AU+ABS BK	
36	ZZ201	PTSPPWK016	SPEAKER AS	DTQ-29U1SC	
37	P601A	4850704S32	CONNECTOR	YH025-04+YRT205+ULW900500	
38	SP01	4858310810	SPEAKER	SP-58126F01	Ⓜ
39	SP02	4858310810	SPEAKER	SP-58126F01	Ⓜ
40	ZZ204	PTJASWJ811	PCB JACK AS	DTQ-29M2	Ⓜ

ELECTRICAL PARTS LIST

NO	LOC	PARTS CODE	PARTS NAME	PARTS DESCRIPTION	REMARK
41	10	2193102005	SOLDER BAR	SN:PB=63:47 S63S-1320	
42	JA02	4859105450	JACK PIN BOARD	YSC03P-4120-9S	
43	M112	4851114003	PANEL AV ASSY	2326802+5934301	
44	M112A	7178301011	SCREW TAPPTITE	TT2 WAS 3X10 MFZN	
45	M684	4856812001	TIE CABLE	NYLON66 DA100	
46	P201A	4850705S04	CONNECTOR	YH025-05+YBNH250+ULW=400	
47	ZZ200	PTJAJAJ811	PCB JACK AXIAL AS	DTQ-29M2	
48	A001	4859802917	PCB JACK	79.05X27.3(197X246/14)C1B	
49	CC608	CCZB1H102K	C CERA	50V B 1000PF K (AXIAL)	
50	CCS07	CCZB1H102K	C CERA	50V B 1000PF K (AXIAL)	
51	RC636	RD-AZ473J-	R CARBON FILM	1/6 47K OHM J	
52	RCS33	RD-AZ473J-	R CARBON FILM	1/6 47K OHM J	
53	ZZ290	PTMPMSK016	PCB MAIN MANUAL AS	DTQ-29U1SC	®
54	10	2193102005	SOLDER BAR	SN:PB=63:47 S63S-1320	
55	30	2291050616	FLUX SOLDER	JS-64T3	
56	40	2291050301	FLUX SOLVENT	IM-1000	
57	C331	CEYD1H689W	C ELECTRO	50V RHD 6.8MF (16X35.5)	
58	C404	CMYH3D722J	C MYLAR	2KV BUP 7200PF J	⚠
59	C406	CMYE2G394J	C MYLAR	400V PU 0.39MF J	
60	C407	CMYH3D752J	C MYLAR	2KV BUP 7500PF J	⚠
61	C409	CMYE2J273J	C MYLAR	630V PU 0.027MF J	
62	C801	CL1UC3104M	C LINE ACROSS	WORLD AC250V 0.1UF M R.47	
63	C804	CEYD2D681D	C ELECTRO	200V FHS 680MF (25X40)	
64	D419	DRGP30J -	DIODE	RGP30J	
65	D424	D D G 3	DIODE	DG3	
66	D703	D L H 2 P R	LED BLOCK	LH-2P-R	
67	D801	PTC1SW8902	HEAT SINK ASS'Y	DPBS606GU- + 7174300811	
68	D801	DPBS606GU-	DIODE BRIDGE	PBS606G	
69	D801A	4857018902	HEAT SINK	A1050P-H24	
70	D801B	7174300811	SCREW TAPPTITE	TT2 RND 3X8 MFZN	
71	D807	PTS2SW6900	HEAT SINK ASS'Y	DFMLG16S + 7128301011	
72	00001	DFMLG16S	DIODE	FML-G16S	
73	0000A	4857026900	HEAT SINK	AL EX	
74	0000B	7174300811	SCREW TAPPTITE	TT2 RND 3X8 MFZN	
75	D842	DRGP30J -	DIODE	RGP30J	
76	F801	5F1GB5021L	FUSE GLASS TUBE	CSA/UL 125V 5A	⚠ ®
77	I201	1MM111 8 -	IC A/V SWITCH	MM1118	®
78	I301	PTC2SW8202	HEAT SINK ASS'Y	1LA7848 - + 7174300811	
79	00001	1LA7848 -	IC VERTICAL	LA7848	®
80	0000A	4857028202	HEAT SINK	AL EX BK	
81	0000B	7174300811	SCREW TAPPTITE	TT2 RND 3X8 MFZN	
82	I401	PTM2SW6902	HEAT SINK ASS'Y	1K78R05 - + 7174300811	
83	00001	1K78R05 -	IC REGULATOR	KIA78R05PI	
84	0000A	4857026902	HEAT SINK	AL EX BK	
85	0000B	7174300811	SCREW TAPPTITE	TT2 RND 3X8 MFZN	

ELECTRICAL PARTS LIST

NO	LOC	PARTS CODE	PARTS NAME	PARTS DESCRIPTION	REMARK
86	I501	1VDP3130Y-	IC	VDP3130Y	Ⓜ
87	I502	1LP295033-	IC REGULATOR	LP2950 3.3V	Ⓜ
88	I601	1MSP3420V3	IC SOUND PROCESSOR	MSP3420G-PP-B8-V3	Ⓜ
89	I602	PTB2SW8216	HEAT SINK ASS'Y	1TDA8944J- + 7174301011	
90	00001	1TDA8944J-	IC SOUND	TDA8944J	Ⓜ
91	0000A	4857028216	HEAT SINK	AL EX	
92	0000B	7174301011	SCREW TAPPTITE	TT2 RND 3X10 MFZN	
93	I701	1DW8638TA1	IC MICOM	LC863856A-51S2	Ⓜ
94	I703	124LC16B1B	IC MEMORY	24LC16B1B	Ⓜ
95	I801	PTD2SW8216	HEAT SINK ASS'Y	1MR2540 - + 7174301011	
96	00001	1MR2540 -	IC POWER	MR2540	⚠ Ⓜ
97	0000A	4857028216	HEAT SINK	AL EX	
98	0000B	7174301011	SCREW TAPPTITE	TT2 RND 3X10 MFZN	
99	I804	1LTV817C	IC PHOTO COUPLER	LTV-817C	⚠
100	I805	1LTV817C	IC PHOTO COUPLER	LTV-817C	⚠
101	IL701	1356VF6 -	IC PREAMP	356VF6	
102	JP01	4859111550	JACK PIN BOARD	YPJ501B	
103	JP02	4859106440	JACK S-VHS	PH-SJ-9503	
104	JP03	4859107050	JACK PIN BOARD	PH-JB-9601 (PH06P-4120-C)	
105	L301	58C7070085	COIL CHOKE	TLN-3062A	
106	L401	58H0000064	COIL H-LINEARITY	TRL-350B	⚠
107	L801	5PLF30A1	FILTER LINE	LF-30A1	⚠
108	M682	4856812001	TIE CABLE	NYLON66 DA100	
109	PWC1	4859907810	CORD POWER AS	ME301P+TER=2100	⚠ Ⓜ
110	Q401	TKTC3229	TR	KTC3229	
111	Q402	PTH2SW7609	HEAT SINK ASS'Y	T2SD2578 + 7174301011	
112	00001	T2SD2578	TR HORI	2SD2578	Ⓜ
113	0000A	4857027609	HEAT SINK	AL EX	
114	0000B	7174301011	SCREW TAPPTITE	TT2 RND 3X10 MFZN	
115	Q804	TKTA1659AY	TR	KTA1659AY	
116	R801	RX10B109JQ	R CEMENT	10W 1 OHM J BEN 25MM 4P	
117	R883	DDB3R0M140	POSISTOR	ECPBD3R0M140	⚠
118	RLY1	5SC0101003	SW RELAY	DG12D1-0(M)-II 1C-1P	⚠
119	RS801	DSVC471D14	VARISTOR	SVC471D14A	
120	SW707	5S50101035	SW TACT	KPT-1112 1C-1P	
121	T401	5TD0000018	TRANS DRIVE	THD-120	
122	T402	50H0000189	FBT	FFA94048L	⚠ Ⓜ
123	T402A	7178301212	SCREW TAPPTITE	TT2 WAS 3X12 MFZN BK	⚠
124	T801	50M5345B9-	TRANS SMPS	TSM-5345B9	⚠ Ⓜ
125	U101	4859723230	TUNER VARACTOR	115-V-F025AR	
126	X501	5XE20R250E	CRYSTAL QUARTZ	HC-49/U 20.2500MHZ 30PPM	
127	X601	5XE18R432E	CRYSTAL QUARTZ	HC-49/U 18.43200MHZ 30PPM	
128	X701	5XYR03276C	CRYSTAL QUARTZ	C-001R 32.768000KHZ 20PPM	
129	ZZ200	PTMPJ2K016	PCB CHIP MOUNT B AS	DTQ-29U1SC	
130	JC002	HRFT000-BA	R CHIP	1/10 0 OHM 1608	

ELECTRICAL PARTS LIST

NO	LOC	PARTS CODE	PARTS NAME	PARTS DESCRIPTION	REMARK
131	JC003	HRFT000-BA	R CHIP	1/10 0 OHM 1608	
132	JC004	HRFT000-BA	R CHIP	1/10 0 OHM 1608	
133	JC005	HRFT000-BA	R CHIP	1/10 0 OHM 1608	
134	JC006	HRFT000-BA	R CHIP	1/10 0 OHM 1608	
135	JC007	HRFT000-BA	R CHIP	1/10 0 OHM 1608	
136	JC008	HRFT000-BA	R CHIP	1/10 0 OHM 1608	
137	JC009	HRFT000-BA	R CHIP	1/10 0 OHM 1608	
138	RC103	HRFT102JBA	R CHIP	1/10 1K OHM J 1608	
139	RC104	HRFT102JBA	R CHIP	1/10 1K OHM J 1608	
140	RC202	HRFT750JBA	R CHIP	1/10 75 OHM J 1608	
141	RC204	HRFT103JBA	R CHIP	1/10 10K OHM J 1608	
142	RC205	HRFT750JBA	R CHIP	1/10 75 OHM J 1608	
143	RC206	HRFT102JBA	R CHIP	1/10 1K OHM J 1608	
144	RC207	HRFT750JBA	R CHIP	1/10 75 OHM J 1608	
145	RC208	HRFT750JBA	R CHIP	1/10 75 OHM J 1608	
146	RC209	HRFT512JBA	R CHIP	1/10 5.1K OHM J 1608	
147	RC210	HRFT750JBA	R CHIP	1/10 75 OHM J 1608	
148	RC211	HRFT102JBA	R CHIP	1/10 1K OHM J 1608	
149	RC212	HRFT101JBA	R CHIP	1/10 100 OHM J 1608	
150	RC213	HRFT750JBA	R CHIP	1/10 75 OHM J 1608	
151	RC214	HRFT101JBA	R CHIP	1/10 100 OHM J 1608	
152	RC310	HRFT103JBA	R CHIP	1/10 10K OHM J 1608	
153	RC311	HRFT363JBA	R CHIP	1/10 36K OHM J 1608	
154	RC312	HRFT133JBA	R CHIP	1/10 13K OHM J 1608	
155	RC351	HRFT362JBA	R CHIP	1/10 3.6K OHM J 1608	
156	RC360	HRFT562JBA	R CHIP	1/10 5.6K OHM J 1608	
157	RC361	HRFT103JBA	R CHIP	1/10 10K OHM J 1608	
158	RC362	HRFT473JBA	R CHIP	1/10 47K OHM J 1608	
159	RC363	HRFT113JBA	R CHIP	1/10 11K OHM J 1608	
160	RC418	HRFT472JBA	R CHIP	1/10 4.7K OHM J 1608	
161	RC454	HRFT391JBA	R CHIP	1/10 390 OHM J 1608	
162	RC455	HRFT331JBA	R CHIP	1/10 330 OHM J 1608	
163	RC501	HRFT101JBA	R CHIP	1/10 100 OHM J 1608	
164	RC502	HRFT101JBA	R CHIP	1/10 100 OHM J 1608	
165	RC503	HRFT101JBA	R CHIP	1/10 100 OHM J 1608	
166	RC504	HRFT103JBA	R CHIP	1/10 10K OHM J 1608	
167	RC507	HRFT102JBA	R CHIP	1/10 1K OHM J 1608	
168	RC509	HRFT303JBA	R CHIP	1/10 30K OHM J 1608	
169	RC518	HRFT682JBA	R CHIP	1/10 6.8K OHM J 1608	
170	RC519	HRFT682JBA	R CHIP	1/10 6.8K OHM J 1608	
171	RC520	HRFT472JBA	R CHIP	1/10 4.7K OHM J 1608	
172	RC523	HRFT472JBA	R CHIP	1/10 4.7K OHM J 1608	
173	RC524	HRFT332JBA	R CHIP	1/10 3.3K OHM J 1608	
174	RC525	HRFT241JBA	R CHIP	1/10 240 OHM J 1608	
175	RC526	HRFT223JBA	R CHIP	1/10 22K OHM J 1608	

ELECTRICAL PARTS LIST

NO	LOC	PARTS CODE	PARTS NAME	PARTS DESCRIPTION	REMARK
176	RC527	HRFT122JBA	R CHIP	1/10 1.2K OHM J 1608	
177	RC532	HRFT101JBA	R CHIP	1/10 100 OHM J 1608	
178	RC534	HRFT103JBA	R CHIP	1/10 10K OHM J 1608	
179	RC541	HRFT101JBA	R CHIP	1/10 100 OHM J 1608	
180	RC542	HRFT101JBA	R CHIP	1/10 100 OHM J 1608	
181	RC543	HRFT101JBA	R CHIP	1/10 100 OHM J 1608	
182	RC549	HRFT750JBA	R CHIP	1/10 75 OHM J 1608	
183	RC551	HRFT750JBA	R CHIP	1/10 75 OHM J 1608	
184	RC553	HRFT101JBA	R CHIP	1/10 100 OHM J 1608	
185	RC554	HRFT102JBA	R CHIP	1/10 1K OHM J 1608	
186	RC556	HRFT680JBA	R CHIP	1/10 68 OHM J 1608	
187	RC557	HRFT223JBA	R CHIP	1/10 22K OHM J 1608	
188	RC560	HRFT133JBA	R CHIP	1/10 13K OHM J 1608	
189	RC561	HRFT102JBA	R CHIP	1/10 1K OHM J 1608	
190	RC562	HRFT102JBA	R CHIP	1/10 1K OHM J 1608	
191	RC601	HRFT101JBA	R CHIP	1/10 100 OHM J 1608	
192	RC602	HRFT101JBA	R CHIP	1/10 100 OHM J 1608	
193	RC603	HRFT103JBA	R CHIP	1/10 10K OHM J 1608	
194	RC604	HRFT102JBA	R CHIP	1/10 1K OHM J 1608	
195	RC606	HRFT102JBA	R CHIP	1/10 1K OHM J 1608	
196	RC611	HRFT101JBA	R CHIP	1/10 100 OHM J 1608	
197	RC612	HRFT101JBA	R CHIP	1/10 100 OHM J 1608	
198	RC613	HRFT101JBA	R CHIP	1/10 100 OHM J 1608	
199	RC614	HRFT101JBA	R CHIP	1/10 100 OHM J 1608	
200	RC615	HRFT101JBA	R CHIP	1/10 100 OHM J 1608	
201	RC616	HRFT101JBA	R CHIP	1/10 100 OHM J 1608	
202	RC623	HRFT102JBA	R CHIP	1/10 1K OHM J 1608	
203	RC628	HRFT101JBA	R CHIP	1/10 100 OHM J 1608	
204	RC629	HRFT101JBA	R CHIP	1/10 100 OHM J 1608	
205	RC702	HRFT473JBA	R CHIP	1/10 47K OHM J 1608	
206	RC704	HRFT101JBA	R CHIP	1/10 100 OHM J 1608	
207	RC705	HRFT472JBA	R CHIP	1/10 4.7K OHM J 1608	
208	RC706	HRFT472JBA	R CHIP	1/10 4.7K OHM J 1608	
209	RC707	HRFT101JBA	R CHIP	1/10 100 OHM J 1608	
210	RC709	HRFT152JBA	R CHIP	1/10 1.5K OHM J 1608	
211	RC711	HRFT102JBA	R CHIP	1/10 1K OHM J 1608	
212	RC712	HRFT101JBA	R CHIP	1/10 100 OHM J 1608	
213	RC713	HRFT101JBA	R CHIP	1/10 100 OHM J 1608	
214	RC721	HRFT102JBA	R CHIP	1/10 1K OHM J 1608	
215	RC723	HRFT101JBA	R CHIP	1/10 100 OHM J 1608	
216	RC724	HRFT102JBA	R CHIP	1/10 1K OHM J 1608	
217	RC732	HRFT102JBA	R CHIP	1/10 1K OHM J 1608	
218	RC733	HRFT102JBA	R CHIP	1/10 1K OHM J 1608	
219	RC734	HRFT102JBA	R CHIP	1/10 1K OHM J 1608	
220	RC735	HRFT102JBA	R CHIP	1/10 1K OHM J 1608	

ELECTRICAL PARTS LIST

NO	LOC	PARTS CODE	PARTS NAME	PARTS DESCRIPTION	REMARK
221	RC736	HRFT103JBA	R CHIP	1/10 10K OHM J 1608	
222	RC737	HRFT103JBA	R CHIP	1/10 10K OHM J 1608	
223	RC738	HRFT471JBA	R CHIP	1/10 470 OHM J 1608	
224	RC742	HRFT102JBA	R CHIP	1/10 1K OHM J 1608	
225	RC743	HRFT102JBA	R CHIP	1/10 1K OHM J 1608	
226	RC744	HRFT102JBA	R CHIP	1/10 1K OHM J 1608	
227	RC745	HRFT512JBA	R CHIP	1/10 5.1K OHM J 1608	
228	RC746	HRFT222JBA	R CHIP	1/10 2.2K OHM J 1608	
229	RC747	HRFT392JBA	R CHIP	1/10 3.9K OHM J 1608	
230	RC748	HRFT472JBA	R CHIP	1/10 4.7K OHM J 1608	
231	RC750	HRFT472JBA	R CHIP	1/10 4.7K OHM J 1608	
232	RC751	HRFT471JBA	R CHIP	1/10 470 OHM J 1608	
233	RC752	HRFT471JBA	R CHIP	1/10 470 OHM J 1608	
234	RC756	HRFT472JBA	R CHIP	1/10 4.7K OHM J 1608	
235	RC757	HRFT472JBA	R CHIP	1/10 4.7K OHM J 1608	
236	RC758	HRFT472JBA	R CHIP	1/10 4.7K OHM J 1608	
237	RC759	HRFT472JBA	R CHIP	1/10 4.7K OHM J 1608	
238	RC769	HRFT102JBA	R CHIP	1/10 1K OHM J 1608	
239	RC780	HRFT101JBA	R CHIP	1/10 100 OHM J 1608	
240	RC782	HRFT331JBA	R CHIP	1/10 330 OHM J 1608	
241	RC784	HRFT514JBA	R CHIP	1/10 510K OHM J 1608	
242	RC785	HRFT101JBA	R CHIP	1/10 100 OHM J 1608	
243	RC786	HRFT102JBA	R CHIP	1/10 1K OHM J 1608	
244	RC787	HRFT472JBA	R CHIP	1/10 4.7K OHM J 1608	
245	RC788	HRFT472JBA	R CHIP	1/10 4.7K OHM J 1608	
246	RC789	HRFT473JBA	R CHIP	1/10 47K OHM J 1608	
247	RC790	HRFT103JBA	R CHIP	1/10 10K OHM J 1608	
248	RC791	HRFT102JBA	R CHIP	1/10 1K OHM J 1608	
249	RC792	HRFT361JBA	R CHIP	1/10 360 OHM J 1608	
250	RC793	HRFT361JBA	R CHIP	1/10 360 OHM J 1608	
251	RC794	HRFT361JBA	R CHIP	1/10 360 OHM J 1608	
252	RC795	HRFT103JBA	R CHIP	1/10 10K OHM J 1608	
253	RC796	HRFT472JBA	R CHIP	1/10 4.7K OHM J 1608	
254	RC797	HRFT471JBA	R CHIP	1/10 470 OHM J 1608	
255	RC798	HRFT103JBA	R CHIP	1/10 10K OHM J 1608	
256	RC806	HRFT102JBA	R CHIP	1/10 1K OHM J 1608	
257	RC869	HRFT154JBA	R CHIP	1/10 150K OHM J 1608	
258	RC871	HRFT102JBA	R CHIP	1/10 1K OHM J 1608	
259	RC872	HRFT122JBA	R CHIP	1/10 1.2K OHM J 1608	
260	RC873	HRFT103JBA	R CHIP	1/10 10K OHM J 1608	
261	RC874	HRFT202JBA	R CHIP	1/10 2K OHM J 1608	
262	RC875	HRFT752JBA	R CHIP	1/10 7.5K OHM J 1608	
263	RC876	HRFT472JBA	R CHIP	1/10 4.7K OHM J 1608	
264	RC877	HRFT103JBA	R CHIP	1/10 10K OHM J 1608	
265	ZZ200	PTMPJ0K016	PCB MAIN (RHU) AS	DTQ-29U1SC	

ELECTRICAL PARTS LIST

NO	LOC	PARTS CODE	PARTS NAME	PARTS DESCRIPTION	REMARK
266	C310	CEXF1E222V	C ELECTRO	25V RSS 2200MF (16X25) TP	
267	C381	CMXM2A224J	C MYLAR	100V 0.22MF J	
268	C405	CEXA2D229E	C ELECTRO	200V RUL 2.2MF (10X16) TP	
269	C414	CEXF1V471V	C ELECTRO	35V RSS 470MF (10X20) TP	
270	C415	CEXF1C102V	C ELECTRO	16V RSS 1000MF (10X20) TP	
271	C420	CEXF2E220V	C ELECTRO	250V RSS 22MF (13X20) TP	
272	C628	CEXF1E222V	C ELECTRO	25V RSS 2200MF (16X25) TP	
273	C630	CMXM2A224J	C MYLAR	100V 0.22MF J	
274	C632	CMXM2A224J	C MYLAR	100V 0.22MF J	
275	C633	CMXM2A224J	C MYLAR	100V 0.22MF J	
276	C634	CMXM2A224J	C MYLAR	100V 0.22MF J	
277	C702	CEXF1C102V	C ELECTRO	16V RSS 1000MF (10X20) TP	
278	C809	CBXB3D102K	C CERA SEMI	2KV BL(N) 1000PF K (T)	
279	C812	CEXF1E222V	C ELECTRO	25V RSS 2200MF (16X25) TP	
280	C813	CBXB3D471K	C CERA SEMI	2KV BL(N) 470PF K (T)	
281	C814	CEXF2C101V	C ELECTRO	160V RSS 100MF (16X25) TP	
282	C815	CEXF2A470V	C ELECTRO	100V RSS 47MF (10X16) TP	
283	C820	CEXF2C101V	C ELECTRO	160V RSS 100MF (16X25) TP	
284	C852	CEXF1E222V	C ELECTRO	25V RSS 2200MF (16X25) TP	
285	C880	CH1BEE472M	C CERA AC	U/C/V 2.5KV 4700PF TP	
286	C881	CH1BEE472M	C CERA AC	U/C/V 2.5KV 4700PF TP	
287	ZZ200	PTMPJBK016	PCB MAIN M-10 AS	DTQ-29U1SC	
288	10	2TM18006BE	TAPE MASKING	6.2X500	
289	E001	4856310300	EYE LET	BSR T0.2 (R1.6)	
290	E002	4856310300	EYE LET	BSR T0.2 (R1.6)	
291	E003	4856310300	EYE LET	BSR T0.2 (R1.6)	
292	E004	4856310300	EYE LET	BSR T0.2 (R1.6)	
293	E005	4856310300	EYE LET	BSR T0.2 (R1.6)	
294	E006	4856310300	EYE LET	BSR T0.2 (R1.6)	
295	E007	4856310300	EYE LET	BSR T0.2 (R1.6)	
296	E008	4856310300	EYE LET	BSR T0.2 (R1.6)	
297	E009	4856310300	EYE LET	BSR T0.2 (R1.6)	
298	E010	4856310300	EYE LET	BSR T0.2 (R1.6)	
299	E011	4856310300	EYE LET	BSR T0.2 (R1.6)	
300	E012	4856310300	EYE LET	BSR T0.2 (R1.6)	
301	E013	4856310300	EYE LET	BSR T0.2 (R1.6)	
302	E014	4856310300	EYE LET	BSR T0.2 (R1.6)	
303	E015	4856310300	EYE LET	BSR T0.2 (R1.6)	
304	E016	4856310300	EYE LET	BSR T0.2 (R1.6)	
305	E017	4856310300	EYE LET	BSR T0.2 (R1.6)	
306	E018	4856310300	EYE LET	BSR T0.2 (R1.6)	
307	E019	4856310300	EYE LET	BSR T0.2 (R1.6)	
308	E020	4856310300	EYE LET	BSR T0.2 (R1.6)	
309	E021	4856310300	EYE LET	BSR T0.2 (R1.6)	
310	E022	4856310300	EYE LET	BSR T0.2 (R1.6)	

ELECTRICAL PARTS LIST

NO	LOC	PARTS CODE	PARTS NAME	PARTS DESCRIPTION	REMARK
311	E023	4856310300	EYE LET	BSR T0.2 (R1.6)	
312	E024	4856310300	EYE LET	BSR T0.2 (R1.6)	
313	E025	4856310300	EYE LET	BSR T0.2 (R1.6)	
314	E026	4856310300	EYE LET	BSR T0.2 (R1.6)	
315	E027	4856310300	EYE LET	BSR T0.2 (R1.6)	
316	E028	4856310300	EYE LET	BSR T0.2 (R1.6)	
317	E029	4856310300	EYE LET	BSR T0.2 (R1.6)	
318	E030	4856310300	EYE LET	BSR T0.2 (R1.6)	
319	E031	4856310300	EYE LET	BSR T0.2 (R1.6)	
320	E101	4856310600	EYE LET	BSR T0.2 (R2.3)	
321	E102	4856310600	EYE LET	BSR T0.2 (R2.3)	
322	E103	4856310600	EYE LET	BSR T0.2 (R2.3)	
323	E104	4856310600	EYE LET	BSR T0.2 (R2.3)	
324	E105	4856310600	EYE LET	BSR T0.2 (R2.3)	
325	E106	4856310600	EYE LET	BSR T0.2 (R2.3)	
326	E107	4856310600	EYE LET	BSR T0.2 (R2.3)	
327	E108	4856310600	EYE LET	BSR T0.2 (R2.3)	
328	E109	4856310600	EYE LET	BSR T0.2 (R2.3)	
329	E110	4856310600	EYE LET	BSR T0.2 (R2.3)	
330	E111	4856310600	EYE LET	BSR T0.2 (R2.3)	
331	E112	4856310600	EYE LET	BSR T0.2 (R2.3)	
332	E113	4856310600	EYE LET	BSR T0.2 (R2.3)	
333	E114	4856310600	EYE LET	BSR T0.2 (R2.3)	
334	E115	4856310600	EYE LET	BSR T0.2 (R2.3)	
335	E116	4856310600	EYE LET	BSR T0.2 (R2.3)	
336	E117	4856310600	EYE LET	BSR T0.2 (R2.3)	
337	E118	4856310600	EYE LET	BSR T0.2 (R2.3)	
338	E119	4856310600	EYE LET	BSR T0.2 (R2.3)	
339	E120	4856310600	EYE LET	BSR T0.2 (R2.3)	
340	E121	4856310600	EYE LET	BSR T0.2 (R2.3)	
341	E122	4856310600	EYE LET	BSR T0.2 (R2.3)	
342	E123	4856310600	EYE LET	BSR T0.2 (R2.3)	
343	E124	4856310600	EYE LET	BSR T0.2 (R2.3)	
344	E125	4856310600	EYE LET	BSR T0.2 (R2.3)	
345	E126	4856310600	EYE LET	BSR T0.2 (R2.3)	
346	N005	4857417500	TERM PIN	DA-IB0214(D2.3/DY PIN)	
347	N006	4857417500	TERM PIN	DA-IB0214(D2.3/DY PIN)	
348	N401	4857417500	TERM PIN	DA-IB0214(D2.3/DY PIN)	
349	N402	4857417500	TERM PIN	DA-IB0214(D2.3/DY PIN)	
350	N403	4857417500	TERM PIN	DA-IB0214(D2.3/DY PIN)	
351	N404	4857417500	TERM PIN	DA-IB0214(D2.3/DY PIN)	
352	P201	485923182S	CONN WAFER	YW025-05 (STICK)	
353	P401	485923202S	CONN WAFER	YW025-07 (STICK)	
354	P501	485923192S	CONN WAFER	YW025-06 (STICK)	
355	P601	485923172S	CONN WAFER	YW025-04 (STICK)	

ELECTRICAL PARTS LIST

NO	LOC	PARTS CODE	PARTS NAME	PARTS DESCRIPTION	REMARK
356	R101	RS02Z181JS	R M-OXIDE FILM	2W 180 OHM J SMALL	
357	R102	RS02Z181JS	R M-OXIDE FILM	2W 180 OHM J SMALL	
358	R106	RS02Z181JS	R M-OXIDE FILM	2W 180 OHM J SMALL	
359	R303	RS02Z109JS	R M-OXIDE FILM	2W 1 OHM J SMALL	
360	R316	RS02Z109JS	R M-OXIDE FILM	2W 1 OHM J SMALL	
361	R411	RF01Z229J-	R FUSIBLE	1W 2.2 OHM J (TAPPING)	
362	R412	RF01Z229J-	R FUSIBLE	1W 2.2 OHM J (TAPPING)	
363	R413	RF01Z159J-	R FUSIBLE	1W 1.5 OHM J (TAPPING)	
364	R414	RF01Z229J-	R FUSIBLE	1W 2.2 OHM J (TAPPING)	
365	R416	RS02Z240JS	R M-OXIDE FILM	2W 24 OHM J SMALL	
366	R617	RS02Z109JS	R M-OXIDE FILM	2W 1 OHM J SMALL	
367	R805	RF02Z128J-	R FUSIBLE	2W 0.12 OHM J (TAPPING)	
368	R814	RF01Z338K-	R FUSIBLE	1W 0.33 OHM K (TAPPING)	
369	ZZ200	PTMPJRK016	PCB MAIN RADIAL AS	DTQ-29U1SC	
370	C101	CEXF1H100V	C ELECTRO	50V RSS 10MF (5X11) TP	
371	C102	CEXF1C101V	C ELECTRO	16V RSS 100MF (6.3X11) TP	
372	C201	CEXF1H100V	C ELECTRO	50V RSS 10MF (5X11) TP	
373	C203	CEXF1H100V	C ELECTRO	50V RSS 10MF (5X11) TP	
374	C204	CEXF1H100V	C ELECTRO	50V RSS 10MF (5X11) TP	
375	C210	CEXF1H470V	C ELECTRO	50V RSS 47MF (6.3X11) TP	
376	C301	CMXM2A103J	C MYLAR	100V 0.01MF J (TP)	
377	C302	CEXF1H479V	C ELECTRO	50V RSS 4.7MF (5X11) TP	
378	C303	CEXF1H100V	C ELECTRO	50V RSS 10MF (5X11) TP	
379	C305	CEXF1H101V	C ELECTRO	50V RSS 100MF (8X11.5) TP	
380	C307	CXSL2H100D	C CERA	500V SL 10PF D (TAPPING)	
381	C308	CMXM2A473J	C MYLAR	100V 0.047MF J (TP)	
382	C311	CEXD1H109Q	C ELECTRO	50V RT 1MF (6.3X11) TP	
383	C312	CEXF1H100V	C ELECTRO	50V RSS 10MF (5X11) TP	
384	C314	CXCH1H200J	C CERA	50V CH 20PF J (TAPPING)	
385	C401	CCXB2H102K	C CERA	500V B 1000PF K (TAPPING)	
386	C402	CCXB2H561K	C CERA	500V B 560PF K (TAPPING)	
387	C403	CMXM2A103J	C MYLAR	100V 0.01MF J (TP)	
388	C411	CEXF1H100V	C ELECTRO	50V RSS 10MF (5X11) TP	
389	C413	CCXB2H102K	C CERA	500V B 1000PF K (TAPPING)	
390	C418	CMXM2A104J	C MYLAR	100V 0.1MF J (TP)	
391	C437	CEXF1E221V	C ELECTRO	25V RSS 220MF (8X11.5) TP	
392	C451	CEXF1C101V	C ELECTRO	16V RSS 100MF (6.3X11) TP	
393	C461	CEXF1H479V	C ELECTRO	50V RSS 4.7MF (5X11) TP	
394	C502	CCXB1H561K	C CERA	50V B 560PF K (TAPPING)	
395	C503	CEXF1C470V	C ELECTRO	16V RSS 47MF (5X11) TP	
396	C506	CEXF1H100V	C ELECTRO	50V RSS 10MF (5X11) TP	
397	C507	CEXF1C101V	C ELECTRO	16V RSS 100MF (6.3X11) TP	
398	C508	CEXF1C221V	C ELECTRO	16V RSS 220MF (8X11.5) TP	
399	C512	CCXB1H122K	C CERA	50V B 1200PF K (TAPPING)	
400	C513	CEXF1C470V	C ELECTRO	16V RSS 47MF (5X11) TP	

ELECTRICAL PARTS LIST

NO	LOC	PARTS CODE	PARTS NAME	PARTS DESCRIPTION	REMARK
401	C519	CEXF1H228V	C ELECTRO	50V RSS 0.22MF (5X11) TP	
402	C521	CEXF1H228V	C ELECTRO	50V RSS 0.22MF (5X11) TP	
403	C523	CEXF1H100V	C ELECTRO	50V RSS 10MF (5X11) TP	
404	C525	CEXF1C470V	C ELECTRO	16V RSS 47MF (5X11) TP	
405	C528	CEXF1H109V	C ELECTRO	50V RSS 1MF (5X11) TP	
406	C529	CEXF1H100V	C ELECTRO	50V RSS 10MF (5X11) TP	
407	C530	CEXF1H109V	C ELECTRO	50V RSS 1MF (5X11) TP	
408	C531	CEXF1H109V	C ELECTRO	50V RSS 1MF (5X11) TP	
409	C532	CMXM2A683J	C MYLAR	100V 0.068MF J (TP)	
410	C534	CEXF1H339V	C ELECTRO	50V RSS 3.3MF (5X11) TP	
411	C538	CMXM2A683J	C MYLAR	100V 0.068MF J (TP)	
412	C540	CXCH1H110J	C CERA	50V CH 11PF J (TAPPING)	
413	C541	CCXB1H561K	C CERA	50V B 560PF K (TAPPING)	
414	C542	CEXF1H229V	C ELECTRO	50V RSS 2.2MF (5X11) TP	
415	C606	CEXF1C470V	C ELECTRO	16V RSS 47MF (5X11) TP	
416	C609	CEXF1H100V	C ELECTRO	50V RSS 10MF (5X11) TP	
417	C610	CEXF1H338V	C ELECTRO	50V RSS 0.33MF (5X11) TP	
418	C611	CEXF1H338V	C ELECTRO	50V RSS 0.33MF (5X11) TP	
419	C612	CEXF1H338V	C ELECTRO	50V RSS 0.33MF (5X11) TP	
420	C613	CEXF1H338V	C ELECTRO	50V RSS 0.33MF (5X11) TP	
421	C614	CEXF1H338V	C ELECTRO	50V RSS 0.33MF (5X11) TP	
422	C615	CEXF1H338V	C ELECTRO	50V RSS 0.33MF (5X11) TP	
423	C618	CEXF1H100V	C ELECTRO	50V RSS 10MF (5X11) TP	
424	C620	CEXF1H100V	C ELECTRO	50V RSS 10MF (5X11) TP	
425	C621	CEXF1C470V	C ELECTRO	16V RSS 47MF (5X11) TP	
426	C623	CEXF1H100V	C ELECTRO	50V RSS 10MF (5X11) TP	
427	C626	CEXF1C470V	C ELECTRO	16V RSS 47MF (5X11) TP	
428	C629	CMXM2A152J	C MYLAR	100V 1500PF J (TP)	
429	C631	CMXM2A152J	C MYLAR	100V 1500PF J (TP)	
430	C635	CEXF1H100V	C ELECTRO	50V RSS 10MF (5X11) TP	
431	C636	CEXF1H229V	C ELECTRO	50V RSS 2.2MF (5X11) TP	
432	C639	CEXF1H338V	C ELECTRO	50V RSS 0.33MF (5X11) TP	
433	C640	CEXF1H338V	C ELECTRO	50V RSS 0.33MF (5X11) TP	
434	C643	CEXF1H229V	C ELECTRO	50V RSS 2.2MF (5X11) TP	
435	C701	CEXF1C101V	C ELECTRO	16V RSS 100MF (6.3X11) TP	
436	C703	CEXF1H100V	C ELECTRO	50V RSS 10MF (5X11) TP	
437	C704	CEXF1H229V	C ELECTRO	50V RSS 2.2MF (5X11) TP	
438	C705	CEXF1H109V	C ELECTRO	50V RSS 1MF (5X11) TP	
439	C706	CEXF1E101V	C ELECTRO	25V RSS 100MF (6.3X11) TP	
440	C710	CEXF1H330V	C ELECTRO	50V RSS 33MF (6.3X11) TP	
441	C742	CEXF1H109V	C ELECTRO	50V RSS 1MF (5X11) TP	
442	C802	CCXB2H222K	C CERA	500V B 2200PF K (TAPPING)	
443	C803	CCXB2H222K	C CERA	500V B 2200PF K (TAPPING)	
444	C810	CEXF1E221V	C ELECTRO	25V RSS 220MF (8X11.5) TP	
445	C818	CEXF1H220V	C ELECTRO	50V RSS 22MF (5X11) TP	

ELECTRICAL PARTS LIST

NO	LOC	PARTS CODE	PARTS NAME	PARTS DESCRIPTION	REMARK
446	C819	CEXF1H470V	C ELECTRO	50V RSS 47MF (6.3X11) TP	
447	C871	CMXM2A682J	C MYLAR	100V 6800PF J (TP)	
448	C892	CMXM2A273J	C MYLAR	100V 0.027MF J (TP)	
449	F801A	4857415001	CLIP FUSE	PFC5000-0702	
450	F801B	4857415001	CLIP FUSE	PFC5000-0702	
451	I803	1KA431L -	IC	KA431L	R
452	L805	58C9430599	COIL CHOKE	AZ-9004Y(94MH)	
453	Q504	TKTA1266Y-	TR	KTA1266Y (TP)	
454	Q505	TKTA1266Y-	TR	KTA1266Y (TP)	
455	Q506	TKTA1266Y-	TR	KTA1266Y (TP)	
456	Q507	TKTC3198Y-	TR	KTC3198Y	
457	Q508	TKTC3198Y-	TR	KTC3198Y	
458	Q509	TKTC3198Y-	TR	KTC3198Y	
459	Q510	TKTC3198Y-	TR	KTC3198Y	
460	Q602	TKTC3198Y-	TR	KTC3198Y	
461	Q701	TKTC3198Y-	TR	KTC3198Y	
462	Q702	TKTC3198Y-	TR	KTC3198Y	
463	Q704	TKTA1266Y-	TR	KTA1266Y (TP)	
464	Q706	TKTC3198Y-	TR	KTC3198Y	
465	Q708	TKTC3198Y-	TR	KTC3198Y	
466	Q802	TKTC3207	TR	KTC3207 (TP)	
467	Q805	TKTC3205Y-	TR	KTC3205Y (TP)	
468	Q871	TKTC3198Y-	TR	KTC3198Y	
469	Q873	TKTC3198Y-	TR	KTC3198Y	
470	R301	RN02B471JS	R METAL FILM	2W 470 OHM J SMALL	
471	R302	RN02B620JS	R METAL FILM	2W 62 OHM J SMALL	
472	R304	RN02B221JS	R METAL FILM	2W 220 OHM J SMALL	
473	R305	RN02B181JS	R METAL FILM	2W 180 OHM J SMALL	
474	R331	RN02B100JS	R METAL FILM	2W 10 OHM J SMALL	
475	R401	RN02B103JS	R METAL FILM	2W 10K OHM J SMALL	
476	R402	RN02B102JS	R METAL FILM	2W 1K OHM J SMALL	
477	R403	RN02B153JS	R METAL FILM	2W 15K OHM J SMALL	
478	R405	RN02B100JS	R METAL FILM	2W 10 OHM J SMALL	
479	R419	RN02B270JS	R METAL FILM	2W 27 OHM J SMALL	
480	R420	RN02B270JS	R METAL FILM	2W 27 OHM J SMALL	
481	R817	RN02B331JS	R METAL FILM	2W 330 OHM J SMALL	
482	SW701	5S50101090	SW TACT	THVH472GCA	
483	SW702	5S50101090	SW TACT	THVH472GCA	
484	SW703	5S50101090	SW TACT	THVH472GCA	
485	SW704	5S50101090	SW TACT	THVH472GCA	
486	SW705	5S50101090	SW TACT	THVH472GCA	
487	SW706	5S50101090	SW TACT	THVH472GCA	
488	ZZ200	PTMPJAK016	PCB MAIN AXIAL AS	DTQ-29U1SC	
489	10	2TM14006LB	TAPE MASKING	3M #232 6.0X2000M	
490	20	2TM10006LB	TAPE MASKING	3M #232-MAP-C 6.2X2000M	

ELECTRICAL PARTS LIST

NO	LOC	PARTS CODE	PARTS NAME	PARTS DESCRIPTION	REMARK
491	A001	4859816791	PCB MAIN	330X246	
492	C103	CCZF1H103Z	C CERA	50V F 0.01MF Z	
493	C107	CCZF1H103Z	C CERA	50V F 0.01MF Z	
494	C211	CCZF1H103Z	C CERA	50V F 0.01MF Z	
495	C212	CCZB1H391K	C CERA	50V B 390PF K (AXIAL)	
496	C213	CCZB1H102K	C CERA	50V B 1000PF K (AXIAL)	
497	C214	CCZB1H102K	C CERA	50V B 1000PF K (AXIAL)	
498	C215	CCZB1H391K	C CERA	50V B 390PF K (AXIAL)	
499	C501	CCZF1H103Z	C CERA	50V F 0.01MF Z	
500	C504	CCZB1H221K	C CERA	50V B 220PF K (AXIAL)	
501	C505	CCZB1H102K	C CERA	50V B 1000PF K (AXIAL)	
502	C509	CCZB1H221K	C CERA	50V B 220PF K (AXIAL)	
503	C510	CCZB1H221K	C CERA	50V B 220PF K (AXIAL)	
504	C511	CCZB1H221K	C CERA	50V B 220PF K (AXIAL)	
505	C514	CCZF1H103Z	C CERA	50V F 0.01MF Z	
506	C515	CCZF1H103Z	C CERA	50V F 0.01MF Z	
507	C516	CCZF1H103Z	C CERA	50V F 0.01MF Z	
508	C517	CZCH1H309C	C CERA	50V CH 3PF C (AXIAL)	
509	C518	CZCH1H309C	C CERA	50V CH 3PF C (AXIAL)	
510	C520	CCZB1H681K	C CERA	50V B 680PF K (AXIAL)	
511	C522	CCZB1H681K	C CERA	50V B 680PF K (AXIAL)	
512	C524	CCZF1H473Z	C CERA	50V F 0.047MF Z	
513	C527	CCZF1H103Z	C CERA	50V F 0.01MF Z	
514	C533	CBZF1H104Z	C CERA SEMI	50V F 0.1MF Z	
515	C535	CCZF1H103Z	C CERA	50V F 0.01MF Z	
516	C536	CCZB1H102K	C CERA	50V B 1000PF K (AXIAL)	
517	C537	CBZF1H104Z	C CERA SEMI	50V F 0.1MF Z	
518	C601	CZCH1H479K	C CERA	50V CH 4.7PF K (AXIAL)	
519	C602	CZCH1H479K	C CERA	50V CH 4.7PF K (AXIAL)	
520	C603	CZSL1H560J	C CERA	50V SL 56PF J (AXIAL)	
521	C604	CZSL1H560J	C CERA	50V SL 56PF J (AXIAL)	
522	C605	CZSL1H560J	C CERA	50V SL 56PF J (AXIAL)	
523	C607	CCZF1H103Z	C CERA	50V F 0.01MF Z	
524	C608	CCZF1H103Z	C CERA	50V F 0.01MF Z	
525	C619	CCZF1H103Z	C CERA	50V F 0.01MF Z	
526	C622	CCZF1H103Z	C CERA	50V F 0.01MF Z	
527	C624	CCZF1H103Z	C CERA	50V F 0.01MF Z	
528	C625	CCZF1H103Z	C CERA	50V F 0.01MF Z	
529	C627	CBZF1H104Z	C CERA SEMI	50V F 0.1MF Z	
530	C641	CCZF1H103Z	C CERA	50V F 0.01MF Z	
531	C642	CCZF1H103Z	C CERA	50V F 0.01MF Z	
532	C651	CCZF1H103Z	C CERA	50V F 0.01MF Z	
533	C752	CZCH1H180J	C CERA	50V CH 18PF J (AXIAL)	
534	C753	CZCH1H180J	C CERA	50V CH 18PF J (AXIAL)	
535	C754	CCZF1H103Z	C CERA	50V F 0.01MF Z	

ELECTRICAL PARTS LIST

NO	LOC	PARTS CODE	PARTS NAME	PARTS DESCRIPTION	REMARK
536	C755	CCZF1H103Z	C CERA	50V F 0.01MF Z	
537	C757	CCZB1H333K	C CERA	50V B 0.033MF K AXL	
538	C780	CCZF1H103Z	C CERA	50V F 0.01MF Z	
539	C891	CCZB1H820K	C CERA	50V B 82PF K (AXIAL)	
540	D101	DUZ33B	DIODE ZENER	UZ-33B	
541	D102	DUZ5R1B -	DIODE ZENER	UZ-5.1B	
542	D201	DUZ6R2BM	DIODE ZENER	UZ-6.2BM	
543	D301	D1N4004S	DIODE	1N4004S	
544	D302	DBZX55C62-	DIODE ZENER	BZX55C-62	
545	D304	D1N4148 -	DIODE	1N4148 (TAPPING)	
546	D401	D1N4937G	DIODE	1N4937G (TAPPING)	
547	D402	DUZ9R1BM	DIODE ZENER	UZ-9.1BM	
548	D405	D1N4937G	DIODE	1N4937G (TAPPING)	
549	D406	D1N4937G	DIODE	1N4937G (TAPPING)	
550	D407	DRGP15J -	DIODE	RGP15J	
551	D408	D1N4937G	DIODE	1N4937G (TAPPING)	
552	D409	D1N4148 -	DIODE	1N4148 (TAPPING)	
553	D461	D1N4148 -	DIODE	1N4148 (TAPPING)	
554	D501	D1N4148 -	DIODE	1N4148 (TAPPING)	
555	D502	D1N4148 -	DIODE	1N4148 (TAPPING)	
556	D503	D1N4148 -	DIODE	1N4148 (TAPPING)	
557	D560	D1N4148 -	DIODE	1N4148 (TAPPING)	
558	D561	D1N4148 -	DIODE	1N4148 (TAPPING)	
559	D601	DUZ8R2BM	DIODE ZENER	UZ-8.2BM	
560	D602	DUZ6R2BM	DIODE ZENER	UZ-6.2BM	
561	D701	D1N4148 -	DIODE	1N4148 (TAPPING)	
562	D704	DUZ3R9B -	DIODE ZENER	UZ-3.9B	
563	D802	DUZ9R1BM	DIODE ZENER	UZ-9.1BM	
564	D803	DUZ9R1BM	DIODE ZENER	UZ-9.1BM	
565	D804	DUZ22BM -	DIODE ZENER	UZ-22BM	
566	D805	DUF4007 -	DIODE	UF4007	
567	D806	D1N4148 -	DIODE	1N4148 (TAPPING)	
568	D808	D1N4937G	DIODE	1N4937G (TAPPING)	
569	D810	DRGP15J -	DIODE	RGP15J	
570	D811	DRGP15J -	DIODE	RGP15J	
571	D812	DUZ5R6BM	DIODE ZENER	UZ-5.6BM	
572	D813	D1N4937G	DIODE	1N4937G (TAPPING)	
573	J001	85801065GY	WIRE COPPER	AWG22 1/0.65 TIN COATING	
574	J002	85801065GY	WIRE COPPER	AWG22 1/0.65 TIN COATING	
575	J003	85801065GY	WIRE COPPER	AWG22 1/0.65 TIN COATING	
576	J004	85801065GY	WIRE COPPER	AWG22 1/0.65 TIN COATING	
577	J005	85801065GY	WIRE COPPER	AWG22 1/0.65 TIN COATING	
578	J006	85801065GY	WIRE COPPER	AWG22 1/0.65 TIN COATING	
579	J007	85801065GY	WIRE COPPER	AWG22 1/0.65 TIN COATING	
580	J008	85801065GY	WIRE COPPER	AWG22 1/0.65 TIN COATING	

ELECTRICAL PARTS LIST

NO	LOC	PARTS CODE	PARTS NAME	PARTS DESCRIPTION	REMARK
581	J009	85801065GY	WIRE COPPER	AWG22 1/0.65 TIN COATING	
582	J010	85801065GY	WIRE COPPER	AWG22 1/0.65 TIN COATING	
583	J011	85801065GY	WIRE COPPER	AWG22 1/0.65 TIN COATING	
584	J012	85801065GY	WIRE COPPER	AWG22 1/0.65 TIN COATING	
585	J013	85801065GY	WIRE COPPER	AWG22 1/0.65 TIN COATING	
586	J014	85801065GY	WIRE COPPER	AWG22 1/0.65 TIN COATING	
587	J015	85801065GY	WIRE COPPER	AWG22 1/0.65 TIN COATING	
588	J016	85801065GY	WIRE COPPER	AWG22 1/0.65 TIN COATING	
589	J017	85801065GY	WIRE COPPER	AWG22 1/0.65 TIN COATING	
590	J018	85801065GY	WIRE COPPER	AWG22 1/0.65 TIN COATING	
591	J019	85801065GY	WIRE COPPER	AWG22 1/0.65 TIN COATING	
592	J020	85801065GY	WIRE COPPER	AWG22 1/0.65 TIN COATING	
593	J021	85801065GY	WIRE COPPER	AWG22 1/0.65 TIN COATING	
594	J022	85801065GY	WIRE COPPER	AWG22 1/0.65 TIN COATING	
595	J023	85801065GY	WIRE COPPER	AWG22 1/0.65 TIN COATING	
596	J024	85801065GY	WIRE COPPER	AWG22 1/0.65 TIN COATING	
597	J025	85801065GY	WIRE COPPER	AWG22 1/0.65 TIN COATING	
598	J026	85801065GY	WIRE COPPER	AWG22 1/0.65 TIN COATING	
599	J027	85801065GY	WIRE COPPER	AWG22 1/0.65 TIN COATING	
600	J028	85801065GY	WIRE COPPER	AWG22 1/0.65 TIN COATING	
601	J029	85801065GY	WIRE COPPER	AWG22 1/0.65 TIN COATING	
602	J030	85801065GY	WIRE COPPER	AWG22 1/0.65 TIN COATING	
603	J031	85801065GY	WIRE COPPER	AWG22 1/0.65 TIN COATING	
604	J032	85801065GY	WIRE COPPER	AWG22 1/0.65 TIN COATING	
605	J033	85801065GY	WIRE COPPER	AWG22 1/0.65 TIN COATING	
606	J034	85801065GY	WIRE COPPER	AWG22 1/0.65 TIN COATING	
607	J035	85801065GY	WIRE COPPER	AWG22 1/0.65 TIN COATING	
608	J036	85801065GY	WIRE COPPER	AWG22 1/0.65 TIN COATING	
609	J037	85801065GY	WIRE COPPER	AWG22 1/0.65 TIN COATING	
610	J038	85801065GY	WIRE COPPER	AWG22 1/0.65 TIN COATING	
611	J039	85801065GY	WIRE COPPER	AWG22 1/0.65 TIN COATING	
612	J040	85801065GY	WIRE COPPER	AWG22 1/0.65 TIN COATING	
613	J041	85801065GY	WIRE COPPER	AWG22 1/0.65 TIN COATING	
614	J042	85801065GY	WIRE COPPER	AWG22 1/0.65 TIN COATING	
615	J043	85801065GY	WIRE COPPER	AWG22 1/0.65 TIN COATING	
616	J044	85801065GY	WIRE COPPER	AWG22 1/0.65 TIN COATING	
617	J045	85801065GY	WIRE COPPER	AWG22 1/0.65 TIN COATING	
618	J046	85801065GY	WIRE COPPER	AWG22 1/0.65 TIN COATING	
619	J047	85801065GY	WIRE COPPER	AWG22 1/0.65 TIN COATING	
620	J048	85801065GY	WIRE COPPER	AWG22 1/0.65 TIN COATING	
621	J049	85801065GY	WIRE COPPER	AWG22 1/0.65 TIN COATING	
622	J050	85801065GY	WIRE COPPER	AWG22 1/0.65 TIN COATING	
623	J051	85801065GY	WIRE COPPER	AWG22 1/0.65 TIN COATING	
624	J052	85801065GY	WIRE COPPER	AWG22 1/0.65 TIN COATING	
625	J053	85801065GY	WIRE COPPER	AWG22 1/0.65 TIN COATING	

ELECTRICAL PARTS LIST

NO	LOC	PARTS CODE	PARTS NAME	PARTS DESCRIPTION	REMARK
626	J054	85801065GY	WIRE COPPER	AWG22 1/0.65 TIN COATING	
627	J055	85801065GY	WIRE COPPER	AWG22 1/0.65 TIN COATING	
628	J056	85801065GY	WIRE COPPER	AWG22 1/0.65 TIN COATING	
629	J057	85801065GY	WIRE COPPER	AWG22 1/0.65 TIN COATING	
630	J058	85801065GY	WIRE COPPER	AWG22 1/0.65 TIN COATING	
631	J059	85801065GY	WIRE COPPER	AWG22 1/0.65 TIN COATING	
632	J060	85801065GY	WIRE COPPER	AWG22 1/0.65 TIN COATING	
633	J061	85801065GY	WIRE COPPER	AWG22 1/0.65 TIN COATING	
634	J062	85801065GY	WIRE COPPER	AWG22 1/0.65 TIN COATING	
635	J063	85801065GY	WIRE COPPER	AWG22 1/0.65 TIN COATING	
636	J064	85801065GY	WIRE COPPER	AWG22 1/0.65 TIN COATING	
637	J065	85801065GY	WIRE COPPER	AWG22 1/0.65 TIN COATING	
638	J066	85801065GY	WIRE COPPER	AWG22 1/0.65 TIN COATING	
639	J067	85801065GY	WIRE COPPER	AWG22 1/0.65 TIN COATING	
640	J068	85801065GY	WIRE COPPER	AWG22 1/0.65 TIN COATING	
641	J069	85801065GY	WIRE COPPER	AWG22 1/0.65 TIN COATING	
642	J070	85801065GY	WIRE COPPER	AWG22 1/0.65 TIN COATING	
643	J071	85801065GY	WIRE COPPER	AWG22 1/0.65 TIN COATING	
644	J072	85801065GY	WIRE COPPER	AWG22 1/0.65 TIN COATING	
645	J073	85801065GY	WIRE COPPER	AWG22 1/0.65 TIN COATING	
646	J074	85801065GY	WIRE COPPER	AWG22 1/0.65 TIN COATING	
647	J075	85801065GY	WIRE COPPER	AWG22 1/0.65 TIN COATING	
648	J076	85801065GY	WIRE COPPER	AWG22 1/0.65 TIN COATING	
649	J077	85801065GY	WIRE COPPER	AWG22 1/0.65 TIN COATING	
650	J078	85801065GY	WIRE COPPER	AWG22 1/0.65 TIN COATING	
651	J079	85801065GY	WIRE COPPER	AWG22 1/0.65 TIN COATING	
652	J080	85801065GY	WIRE COPPER	AWG22 1/0.65 TIN COATING	
653	J081	85801065GY	WIRE COPPER	AWG22 1/0.65 TIN COATING	
654	J082	85801065GY	WIRE COPPER	AWG22 1/0.65 TIN COATING	
655	J083	85801065GY	WIRE COPPER	AWG22 1/0.65 TIN COATING	
656	J084	85801065GY	WIRE COPPER	AWG22 1/0.65 TIN COATING	
657	J085	85801065GY	WIRE COPPER	AWG22 1/0.65 TIN COATING	
658	J086	85801065GY	WIRE COPPER	AWG22 1/0.65 TIN COATING	
659	J087	85801065GY	WIRE COPPER	AWG22 1/0.65 TIN COATING	
660	J088	85801065GY	WIRE COPPER	AWG22 1/0.65 TIN COATING	
661	J089	85801065GY	WIRE COPPER	AWG22 1/0.65 TIN COATING	
662	J090	85801065GY	WIRE COPPER	AWG22 1/0.65 TIN COATING	
663	J091	85801065GY	WIRE COPPER	AWG22 1/0.65 TIN COATING	
664	J092	85801065GY	WIRE COPPER	AWG22 1/0.65 TIN COATING	
665	J093	85801065GY	WIRE COPPER	AWG22 1/0.65 TIN COATING	
666	J094	85801065GY	WIRE COPPER	AWG22 1/0.65 TIN COATING	
667	J095	85801065GY	WIRE COPPER	AWG22 1/0.65 TIN COATING	
668	J096	85801065GY	WIRE COPPER	AWG22 1/0.65 TIN COATING	
669	J097	85801065GY	WIRE COPPER	AWG22 1/0.65 TIN COATING	
670	J098	85801065GY	WIRE COPPER	AWG22 1/0.65 TIN COATING	

ELECTRICAL PARTS LIST

NO	LOC	PARTS CODE	PARTS NAME	PARTS DESCRIPTION	REMARK
671	J099	85801065GY	WIRE COPPER	AWG22 1/0.65 TIN COATING	
672	J100	85801065GY	WIRE COPPER	AWG22 1/0.65 TIN COATING	
673	J101	85801065GY	WIRE COPPER	AWG22 1/0.65 TIN COATING	
674	J102	85801065GY	WIRE COPPER	AWG22 1/0.65 TIN COATING	
675	J103	85801065GY	WIRE COPPER	AWG22 1/0.65 TIN COATING	
676	J104	85801065GY	WIRE COPPER	AWG22 1/0.65 TIN COATING	
677	J105	85801065GY	WIRE COPPER	AWG22 1/0.65 TIN COATING	
678	J106	85801065GY	WIRE COPPER	AWG22 1/0.65 TIN COATING	
679	J107	85801065GY	WIRE COPPER	AWG22 1/0.65 TIN COATING	
680	J108	85801065GY	WIRE COPPER	AWG22 1/0.65 TIN COATING	
681	J109	85801065GY	WIRE COPPER	AWG22 1/0.65 TIN COATING	
682	J110	85801065GY	WIRE COPPER	AWG22 1/0.65 TIN COATING	
683	J111	85801065GY	WIRE COPPER	AWG22 1/0.65 TIN COATING	
684	J112	85801065GY	WIRE COPPER	AWG22 1/0.65 TIN COATING	
685	J113	85801065GY	WIRE COPPER	AWG22 1/0.65 TIN COATING	
686	J114	85801065GY	WIRE COPPER	AWG22 1/0.65 TIN COATING	
687	J115	85801065GY	WIRE COPPER	AWG22 1/0.65 TIN COATING	
688	J116	85801065GY	WIRE COPPER	AWG22 1/0.65 TIN COATING	
689	J117	85801065GY	WIRE COPPER	AWG22 1/0.65 TIN COATING	
690	J118	85801065GY	WIRE COPPER	AWG22 1/0.65 TIN COATING	
691	J119	85801065GY	WIRE COPPER	AWG22 1/0.65 TIN COATING	
692	J120	85801065GY	WIRE COPPER	AWG22 1/0.65 TIN COATING	
693	J121	85801065GY	WIRE COPPER	AWG22 1/0.65 TIN COATING	
694	J122	85801065GY	WIRE COPPER	AWG22 1/0.65 TIN COATING	
695	J123	85801065GY	WIRE COPPER	AWG22 1/0.65 TIN COATING	
696	J124	85801065GY	WIRE COPPER	AWG22 1/0.65 TIN COATING	
697	J125	85801065GY	WIRE COPPER	AWG22 1/0.65 TIN COATING	
698	J126	85801065GY	WIRE COPPER	AWG22 1/0.65 TIN COATING	
699	J127	85801065GY	WIRE COPPER	AWG22 1/0.65 TIN COATING	
700	J128	85801065GY	WIRE COPPER	AWG22 1/0.65 TIN COATING	
701	J129	85801065GY	WIRE COPPER	AWG22 1/0.65 TIN COATING	
702	J130	85801065GY	WIRE COPPER	AWG22 1/0.65 TIN COATING	
703	J131	85801065GY	WIRE COPPER	AWG22 1/0.65 TIN COATING	
704	J132	85801065GY	WIRE COPPER	AWG22 1/0.65 TIN COATING	
705	J133	85801065GY	WIRE COPPER	AWG22 1/0.65 TIN COATING	
706	J134	85801065GY	WIRE COPPER	AWG22 1/0.65 TIN COATING	
707	J135	85801065GY	WIRE COPPER	AWG22 1/0.65 TIN COATING	
708	J136	85801065GY	WIRE COPPER	AWG22 1/0.65 TIN COATING	
709	J137	85801065GY	WIRE COPPER	AWG22 1/0.65 TIN COATING	
710	J138	85801065GY	WIRE COPPER	AWG22 1/0.65 TIN COATING	
711	J139	85801065GY	WIRE COPPER	AWG22 1/0.65 TIN COATING	
712	J140	85801065GY	WIRE COPPER	AWG22 1/0.65 TIN COATING	
713	J141	85801065GY	WIRE COPPER	AWG22 1/0.65 TIN COATING	
714	J142	85801065GY	WIRE COPPER	AWG22 1/0.65 TIN COATING	
715	J143	85801065GY	WIRE COPPER	AWG22 1/0.65 TIN COATING	

ELECTRICAL PARTS LIST

NO	LOC	PARTS CODE	PARTS NAME	PARTS DESCRIPTION	REMARK
716	J144	85801065GY	WIRE COPPER	AWG22 1/0.65 TIN COATING	
717	J145	85801065GY	WIRE COPPER	AWG22 1/0.65 TIN COATING	
718	J146	85801065GY	WIRE COPPER	AWG22 1/0.65 TIN COATING	
719	J147	85801065GY	WIRE COPPER	AWG22 1/0.65 TIN COATING	
720	J148	85801065GY	WIRE COPPER	AWG22 1/0.65 TIN COATING	
721	J149	85801065GY	WIRE COPPER	AWG22 1/0.65 TIN COATING	
722	J150	85801065GY	WIRE COPPER	AWG22 1/0.65 TIN COATING	
723	J151	85801065GY	WIRE COPPER	AWG22 1/0.65 TIN COATING	
724	J152	85801065GY	WIRE COPPER	AWG22 1/0.65 TIN COATING	
725	J153	85801065GY	WIRE COPPER	AWG22 1/0.65 TIN COATING	
726	J154	85801065GY	WIRE COPPER	AWG22 1/0.65 TIN COATING	
727	J155	85801065GY	WIRE COPPER	AWG22 1/0.65 TIN COATING	
728	J156	85801065GY	WIRE COPPER	AWG22 1/0.65 TIN COATING	
729	J601	85801065GY	WIRE COPPER	AWG22 1/0.65 TIN COATING	
730	J602	85801065GY	WIRE COPPER	AWG22 1/0.65 TIN COATING	
731	J801	85801065GY	WIRE COPPER	AWG22 1/0.65 TIN COATING	
732	J802	85801065GY	WIRE COPPER	AWG22 1/0.65 TIN COATING	
733	L201	5CPZ120K02	COIL PEAKING	12UH K (AXIAL 3.5MM)	
734	L202	5CPZ120K02	COIL PEAKING	12UH K (AXIAL 3.5MM)	
735	L406	85801065GY	WIRE COPPER	AWG22 1/0.65 TIN COATING	
736	L501	5CPZ568M02	COIL PEAKING	0.56UH M (AXIAL 3.5MM)	
737	L502	5CPZ568M02	COIL PEAKING	0.56UH M (AXIAL 3.5MM)	
738	L503	5CPZ689K02	COIL PEAKING	6.8UH K (AXIAL 3.5MM)	
739	L504	5CPZ689K02	COIL PEAKING	6.8UH K (AXIAL 3.5MM)	
740	L505	5CPZ568M02	COIL PEAKING	0.56UH M (AXIAL 3.5MM)	
741	L601	5CPZ150K02	COIL PEAKING	15UH K (AXIAL 3.5MM)	
742	L602	5CPZ568M02	COIL PEAKING	0.56UH M (AXIAL 3.5MM)	
743	L603	5CPZ568M02	COIL PEAKING	0.56UH M (AXIAL 3.5MM)	
744	L604	5MC0000100	COIL BEAD	HC-3550	
745	L607	5MC0000100	COIL BEAD	HC-3550	
746	L701	5CPZ220K02	COIL PEAKING	22UH K (AXIAL 3.5MM)	
747	L802	5MC0000100	COIL BEAD	HC-3550	
748	L806	5MC0000100	COIL BEAD	HC-3550	
749	L807	5MC0000100	COIL BEAD	HC-3550	
750	L808	5MC0000100	COIL BEAD	HC-3550	
751	L809	5MC0000100	COIL BEAD	HC-3550	
752	R105	RD-2Z392J-	R CARBON FILM	1/2 3.9K OHM J	
753	R201	RD-4Z241J-	R CARBON FILM	1/4 240 OHM J	
754	R203	RD-AZ750J-	R CARBON FILM	1/6 75 OHM J	
755	R313	RD-AZ913J-	R CARBON FILM	1/6 91K OHM J	
756	R352	RN-AZ1003F	R METAL FILM	1/6 100K OHM F	
757	R353	RN-AZ1102F	R METAL FILM	1/6 11.0K OHM F	
758	R359	RD-AZ623J-	R CARBON FILM	1/6 62K OHM J	
759	R371	RD-AZ914J-	R CARBON FILM	1/6 910K OHM J	
760	R404	RD-4Z220J-	R CARBON FILM	1/4 22 OHM J	

ELECTRICAL PARTS LIST

NO	LOC	PARTS CODE	PARTS NAME	PARTS DESCRIPTION	REMARK
761	R450	RD-4Z472J-	R CARBON FILM	1/4 4.7K OHM J	
762	R451	RN-4Z1802F	R METAL FILM	1/4 18.0K OHM F	
763	R452	RN-4Z1802F	R METAL FILM	1/4 18.0K OHM F	
764	R535	RD-AZ151J-	R CARBON FILM	1/6 150 OHM J	
765	R536	RD-AZ151J-	R CARBON FILM	1/6 150 OHM J	
766	R537	RD-AZ151J-	R CARBON FILM	1/6 150 OHM J	
767	R538	RD-AZ221J-	R CARBON FILM	1/6 220 OHM J	
768	R539	RD-AZ221J-	R CARBON FILM	1/6 220 OHM J	
769	R540	RD-AZ221J-	R CARBON FILM	1/6 220 OHM J	
770	R544	RD-AZ330J-	R CARBON FILM	1/6 33 OHM J	
771	R545	RD-AZ330J-	R CARBON FILM	1/6 33 OHM J	
772	R546	RD-AZ330J-	R CARBON FILM	1/6 33 OHM J	
773	R547	RD-AZ392J-	R CARBON FILM	1/6 3.9K OHM J	
774	R548	RD-AZ220J-	R CARBON FILM	1/6 22 OHM J	
775	R550	RD-AZ271J-	R CARBON FILM	1/6 270 OHM J	
776	R555	RD-AZ750J-	R CARBON FILM	1/6 75 OHM J	
777	R558	RD-AZ101J-	R CARBON FILM	1/6 100 OHM J	
778	R559	RD-AZ221J-	R CARBON FILM	1/6 220 OHM J	
779	R605	RD-AZ162J-	R CARBON FILM	1/6 1.6K OHM J	
780	R607	RD-AZ162J-	R CARBON FILM	1/6 1.6K OHM J	
781	R608	RD-2Z111J-	R CARBON FILM	1/2 110 OHM J	
782	R701	RD-AZ479J-	R CARBON FILM	1/6 4.7 OHM J	
783	R703	RD-AZ101J-	R CARBON FILM	1/6 100 OHM J	
784	R762	RD-AZ511J-	R CARBON FILM	1/6 510 OHM J	
785	R802	RN-AZ5601F	R METAL FILM	1/6 5.6K OHM F	
786	R804	RD-2Z105J-	R CARBON FILM	1/2 1M OHM J	
787	R813	RD-AZ363J-	R CARBON FILM	1/6 36K OHM J	
788	R818	RD-AZ561J-	R CARBON FILM	1/6 560 OHM J	
789	R822	RD-AZ223J-	R CARBON FILM	1/6 22K OHM J	
790	R862	RD-AZ203J-	R CARBON FILM	1/6 20K OHM J	
791	R863	RD-AZ203J-	R CARBON FILM	1/6 20K OHM J	
792	R868	RN-AZ2201F	R METAL FILM	1/6 2.2K OHM F	
793	R870	RN-AZ1202F	R METAL FILM	1/6 12K OHM F	
794	R878	RN-AZ5102F	R METAL FILM	1/6 51.0K OHM F	
795	R879	RN-AZ5102F	R METAL FILM	1/6 51.0K OHM F	
796	R881	RC-2Z565KP	R CARBON COMP	1/2 5.6M OHM K	
797	R884	RC-2Z225KP	R CARBON COMP	1/2 2.2M OHM K	
798	R891	RD-AZ100J-	R CARBON FILM	1/6 10 OHM J	
799	R892	RD-AZ203J-	R CARBON FILM	1/6 20K OHM J	
800	R893	RN-AZ2002F	R METAL FILM	1/6 20.0K OHM F	
801	ZZ300	PTCPMSK016	PCB CRT MANUAL AS	DTQ-29U1SC	
802	I901	PTB2SW5403	HEAT SINK ASS'Y	1TEA5101B- + 7174300811	
803	I901	1TEA5101B-	IC VIDEO AMP	TEA5101B	®
804	I901A	4857025403	HEAT SINK	AL050P-H24 T=2T=2	
805	I901B	7174300811	SCREW TAPPTITE	TT2 RND 3X8 MFZN	

ELECTRICAL PARTS LIST

NO	LOC	PARTS CODE	PARTS NAME	PARTS DESCRIPTION	REMARK
806	M684	4856812001	TIE CABLE	NYLON66 DA100	
807	P903	4859238620	CONN WAFER	YPW500-02	
808	P904	4859205620	CONN WAFER	LW-0640-03	
809	PA401	4850707S02	CONNECTOR	YH025-07+YST025+ULW=400	
810	PA501	4850706S02	CONNECTOR	YH025-06+YBNH025-06+ULW=400	
811	Q908	PTE2SW6901	HEAT SINK ASS'Y	TKTA1659Y- + 7174300811	
812	00001	TKTA1659AY	TR	KTA1659AY	
813	0000A	4857026901	HEAT SINK	AL EX BK	
814	0000B	7174300811	SCREW TAPPTITE	TT2 RND 3X8 MFZN	
815	Q909	PTB2SW6900	HEAT SINK ASS'Y	TKTC4370Y- + 7174300811	
816	0000A	4857026900	HEAT SINK	AL EX	
817	0000B	7174300811	SCREW TAPPTITE	TT2 RND 3X8 MFZN	
818	00001	TKTC4370AY	TR	KTC4370AY	
819	SCT1	4859302830	SOCKET CRT	ISH-02S	®
820	ZZ200	PTCPJ0K016	PCB CRT ODD SHAPE AS	DTQ-29U1SC	
821	C907	CEXF2E100V	C ELECTRO	250V RSS 10MF (10X20) TP	
822	C908	CEXF2E100V	C ELECTRO	250V RSS 10MF (10X20) TP	
823	C909	CH1BEE472M	C CERA AC	U/C/V 2.5KV 4700PF TP	
824	C941	CEXF2C470V	C ELECTRO	160V RSS 47MF (13X25) TP	
825	C942	CEXF2C100V	C ELECTRO	160V RSS 10MF (10X16) TP	
826	C943	CEXF2C470V	C ELECTRO	160V RSS 47MF (13X25) TP	
827	C945	CEXF2C100V	C ELECTRO	160V RSS 10MF (10X16) TP	
828	ZZ200	PTCPJBK016	PCB CRT M-10 AS	DTQ-29U1SC	
829	R904	RS01Z683J-	R M-OXIDE FILM	1W 68K OHM J (TAPPING)	
830	R907	RS01Z683J-	R M-OXIDE FILM	1W 68K OHM J (TAPPING)	
831	R910	RS01Z683J-	R M-OXIDE FILM	1W 68K OHM J (TAPPING)	
832	R951	RS01Z331J-	R M-OXIDE FILM	1W 330 OHM J (TAPPING)	
833	R954	RS02Z209JS	R M-OXIDE FILM	2W 2 OHM J SMALL	
834	R956	RS02Z102JS	R M-OXIDE FILM	2W 1K OHM J SMALL	
835	ZZ200	PTCPJRK016	PCB CRT RADIAL AS	DTQ-29U1SC	
836	C901	CEXF1H100C	C ELECTRO	50V RUS 10MF (5X11) TP	
837	C902	CMXM2A104J	C MYLAR	100V 0.1MF J (TP)	
838	C904	CCXB2H102K	C CERA	500V B 1000PF K (TAPPING)	
839	C905	CCXB2H102K	C CERA	500V B 1000PF K (TAPPING)	
840	C906	CCXB2H102K	C CERA	500V B 1000PF K (TAPPING)	
841	C915	CMXM2A822J	C MYLAR	100V 8200PF J (TP)	
842	C916	CEXF1E470C	C ELECTRO	25V RUS 47MF (5X11) TP	
843	C920	CEXF1E470C	C ELECTRO	25V RUS 47MF (5X11) TP	
844	C922	CCXB1H472K	C CERA	50V B 4700PF K (TAPPING)	
845	C923	CCXB1H472K	C CERA	50V B 4700PF K (TAPPING)	
846	C944	CXSL2H470J	C CERA	500V SL 47PF J (TAPPING)	
847	C946	CEXF1C221V	C ELECTRO	16V RSS 220MF (8X11.5) TP	
848	C947	CMXL2E104K	C MYLAR	250V MEU 0.1MF K	
849	G901	4SG0DX0001	SPARK GAP	SSG-102-A1(1.0KV) TAP	
850	G902	4SG0DX0001	SPARK GAP	SSG-102-A1(1.0KV) TAP	

ELECTRICAL PARTS LIST

NO	LOC	PARTS CODE	PARTS NAME	PARTS DESCRIPTION	REMARK
851	G903	4SG0DX0001	SPARK GAP	SSG-102-A1(1.0KV) TAP	
852	Q902	TKTC3198Y-	TR	KTC3198Y	
853	Q903	TKTC3198Y-	TR	KTC3198Y	
854	Q904	TKTC3198Y-	TR	KTC3198Y	
855	Q905	TKTC3198Y-	TR	KTC3198Y	
856	Q906	TKTC3198Y-	TR	KTC3198Y	
857	Q907	TKTA1266Y-	TR	KTA1266Y (TP)	
858	Q910	TKTA1266Y-	TR	KTA1266Y (TP)	
859	R903	RN02B240JS	R METAL FILM	2W 24 OHM J SMALL	
860	R953	RN02B221JS	R METAL FILM	2W 220 OHM J SMALL	
861	ZZ200	PTCPJAK016	PCB CRT AXIAL AS	DTQ-29U1SC	
862	A001	4859828413	PCB CRT	165X113(330X246/2X2) C1B	
863	C917	CCZB1H561K	C CERA	50V B 560PF K	
864	C918	CCZF1H103Z	C CERA	50V F 0.01MF Z	
865	C919	CCZB1H102K	C CERA	50V B 1000PF K (AXIAL)	
866	C921	CCZB1H101K	C CERA	50V B 100PF K (AXIAL)	
867	C924	CCZB1H101K	C CERA	50V B 100PF K (AXIAL)	
868	D901	D1N4148 -	DIODE	1N4148 (TAPPING)	
869	D902	D1N4148 -	DIODE	1N4148 (TAPPING)	
870	D903	D1N4148 -	DIODE	1N4148 (TAPPING)	
871	D904	DLT2A05G	DIODE	LT2A05G (TP)	
872	D905	DUZ12BM -	DIODE ZENER	UZ-12BM (UNIZON)	
873	D906	D1N4148 -	DIODE	1N4148 (TAPPING)	
874	D907	D1N4148 -	DIODE	1N4148 (TAPPING)	
875	D908	D1N4148 -	DIODE	1N4148 (TAPPING)	
876	D909	D1N4148 -	DIODE	1N4148 (TAPPING)	
877	D910	D1N4148 -	DIODE	1N4148 (TAPPING)	
878	D911	D1N4004S	DIODE	1N4004S	
879	D912	D1N4004S	DIODE	1N4004S	
880	D913	DUZ9R1BM	DIODE ZENER	UZ-9.1BM	
881	D914	D1N4148 -	DIODE	1N4148 (TAPPING)	
882	D915	D1N4148 -	DIODE	1N4148 (TAPPING)	
883	D916	D1N4148 -	DIODE	1N4148 (TAPPING)	
884	D917	D1N4148 -	DIODE	1N4148 (TAPPING)	
885	D918	DUZ5R6BM	DIODE ZENER	UZ-5.6BM	
886	D919	DUZ5R6BM	DIODE ZENER	UZ-5.6BM	
887	D920	D1N4937G	DIODE	1N4937G (TAPPING)	
888	D921	D1N4937G	DIODE	1N4937G (TAPPING)	
889	D922	D1N4937G	DIODE	1N4937G (TAPPING)	
890	J901	85801065GY	WIRE COPPER	AWG22 1/0.65 TIN COATING	
891	J902	85801065GY	WIRE COPPER	AWG22 1/0.65 TIN COATING	
892	J904	85801065GY	WIRE COPPER	AWG22 1/0.65 TIN COATING	
893	J905	85801065GY	WIRE COPPER	AWG22 1/0.65 TIN COATING	
894	J906	85801065GY	WIRE COPPER	AWG22 1/0.65 TIN COATING	
895	J907	85801065GY	WIRE COPPER	AWG22 1/0.65 TIN COATING	

ELECTRICAL PARTS LIST

NO	LOC	PARTS CODE	PARTS NAME	PARTS DESCRIPTION	REMARK
896	J908	85801065GY	WIRE COPPER	AWG22 1/0.65 TIN COATING	
897	J910	85801065GY	WIRE COPPER	AWG22 1/0.65 TIN COATING	
898	J913	85801065GY	WIRE COPPER	AWG22 1/0.65 TIN COATING	
899	J914	85801065GY	WIRE COPPER	AWG22 1/0.65 TIN COATING	
900	J915	85801065GY	WIRE COPPER	AWG22 1/0.65 TIN COATING	
901	J916	85801065GY	WIRE COPPER	AWG22 1/0.65 TIN COATING	
902	J918	85801065GY	WIRE COPPER	AWG22 1/0.65 TIN COATING	
903	J922	85801065GY	WIRE COPPER	AWG22 1/0.65 TIN COATING	
904	L901	5MC0000100	COIL BEAD	HC-3550	
905	L902	5MC0000100	COIL BEAD	HC-3550	
906	L903	5MC0000100	COIL BEAD	HC-3550	
907	R905	RD-AZ391J-	R CARBON FILM	1/6 390 OHM J	
908	R906	RD-AZ472J-	R CARBON FILM	1/6 4.7K OHM J	
909	R908	RD-AZ391J-	R CARBON FILM	1/6 390 OHM J	
910	R909	RD-AZ472J-	R CARBON FILM	1/6 4.7K OHM J	
911	R911	RD-AZ391J-	R CARBON FILM	1/6 390 OHM J	
912	R912	RD-AZ472J-	R CARBON FILM	1/6 4.7K OHM J	
913	R913	RD-AZ751J-	R CARBON FILM	1/6 750 OHM J	
914	R914	RD-AZ472J-	R CARBON FILM	1/6 4.7K OHM J	
915	R915	RD-AZ751J-	R CARBON FILM	1/6 750 OHM J	
916	R916	RD-AZ472J-	R CARBON FILM	1/6 4.7K OHM J	
917	R917	RD-AZ751J-	R CARBON FILM	1/6 750 OHM J	
918	R918	RD-AZ472J-	R CARBON FILM	1/6 4.7K OHM J	
919	R919	RC-2Z272K-	R CARBON COMP	1/2 2.7K OHM K	
920	R920	RC-2Z272K-	R CARBON COMP	1/2 2.7K OHM K	
921	R921	RC-2Z272K-	R CARBON COMP	1/2 2.7K OHM K	
922	R922	RD-2Z100J-	R CARBON FILM	1/2 10 OHM J	
923	R924	RD-AZ102J-	R CARBON FILM	1/6 1K OHM J	
924	R925	RD-AZ471J-	R CARBON FILM	1/6 470 OHM J	
925	R926	RD-2Z471J-	R CARBON FILM	1/2 470 OHM J	
926	R927	RD-AZ470J-	R CARBON FILM	1/6 47 OHM J	
927	R928	RD-AZ223J-	R CARBON FILM	1/6 22K OHM J	
928	R929	RD-AZ273J-	R CARBON FILM	1/6 27K OHM J	
929	R930	RD-AZ333J-	R CARBON FILM	1/6 33K OHM J	
930	R932	RD-AZ392J-	R CARBON FILM	1/6 3.9K OHM J	
931	R933	RD-AZ392J-	R CARBON FILM	1/6 3.9K OHM J	
932	R934	RD-AZ393J-	R CARBON FILM	1/6 39K OHM J	
933	R935	RD-AZ563J-	R CARBON FILM	1/6 56K OHM J	
934	R936	RD-AZ103J-	R CARBON FILM	1/6 10K OHM J	
935	R937	RD-AZ820J-	R CARBON FILM	1/6 82 OHM J	
936	R938	RD-2Z100J-	R CARBON FILM	1/2 10 OHM J	
937	R939	RD-AZ820J-	R CARBON FILM	1/6 82 OHM J	
938	R940	RD-AZ122J-	R CARBON FILM	1/6 1.2K OHM J	
939	R941	RD-AZ152J-	R CARBON FILM	1/6 1.5K OHM J	
940	R942	RD-AZ683J-	R CARBON FILM	1/6 68K OHM J	

ELECTRICAL PARTS LIST

NO	LOC	PARTS CODE	PARTS NAME	PARTS DESCRIPTION	REMARK
941	R943	RD-AZ683J-	R CARBON FILM	1/6 68K OHM J	
942	R944	RD-AZ123J-	R CARBON FILM	1/6 12K OHM J	
943	R945	RD-AZ122J-	R CARBON FILM	1/6 1.2K OHM J	
944	R946	RD-AZ152J-	R CARBON FILM	1/6 1.5K OHM J	
945	R947	RD-4Z620J-	R CARBON FILM	1/4 62 OHM J	
946	R948	RD-2Z279J-	R CARBON FILM	1/2 2.7 OHM J	
947	R950	RD-2Z279J-	R CARBON FILM	1/2 2.7 OHM J	
948	R952	RD-4Z620J-	R CARBON FILM	1/4 62 OHM J	
949	R955	RD-AZ182J-	R CARBON FILM	1/6 1.8K OHM J	
950	R957	RD-4Z105J-	R CARBON FILM	1/4 1M OHM J	
951	R958	RD-2Z102J-	R CARBON FILM	1/2 1K OHM J	
952	R959	RD-AZ101J-	R CARBON FILM	1/6 100 OHM J	

DIFFERENT PARTS LIST

**This BOM is based on DTQ-29U1SC, it is different parts list in comparison with DTQ-29U5SC.

NO	LOC	PARTS CODE	PARTS NAME	PARTS DESCRIPTION	REMARK
1	M191	4851948400	BUTTON CTRL	4955100+5549200 29U1	29U1
2		4854955500	BUTTON CH	FR ABS GY 29U5	29U5
3	M192	NONE			29U1
4		4855549700	DECO SENSOR	PC SMOG 29U5	29U5
5	M201	4852083500	MASK FRONT	FR HIPS GY 29U1	29U1
6		4852084000	MASK FRONT	FR HIPS GY 29U5	29U5
7	M481	4854864100	BUTTON POWER	FR HIPS GY 29U1	29U1
8		4854864600	BUTTON POWER	FR HIPS GY 29U5	29U5
9	M811	4858101100	PAD	EPS 29U1	29U1
10		4858101600	PAD	EPS 29U5	29U5

**This BOM is based on DTQ-29U1SC, it is different parts list in comparison with DTQ-29U1SSP.

SCHEMATIC DIAGRAM

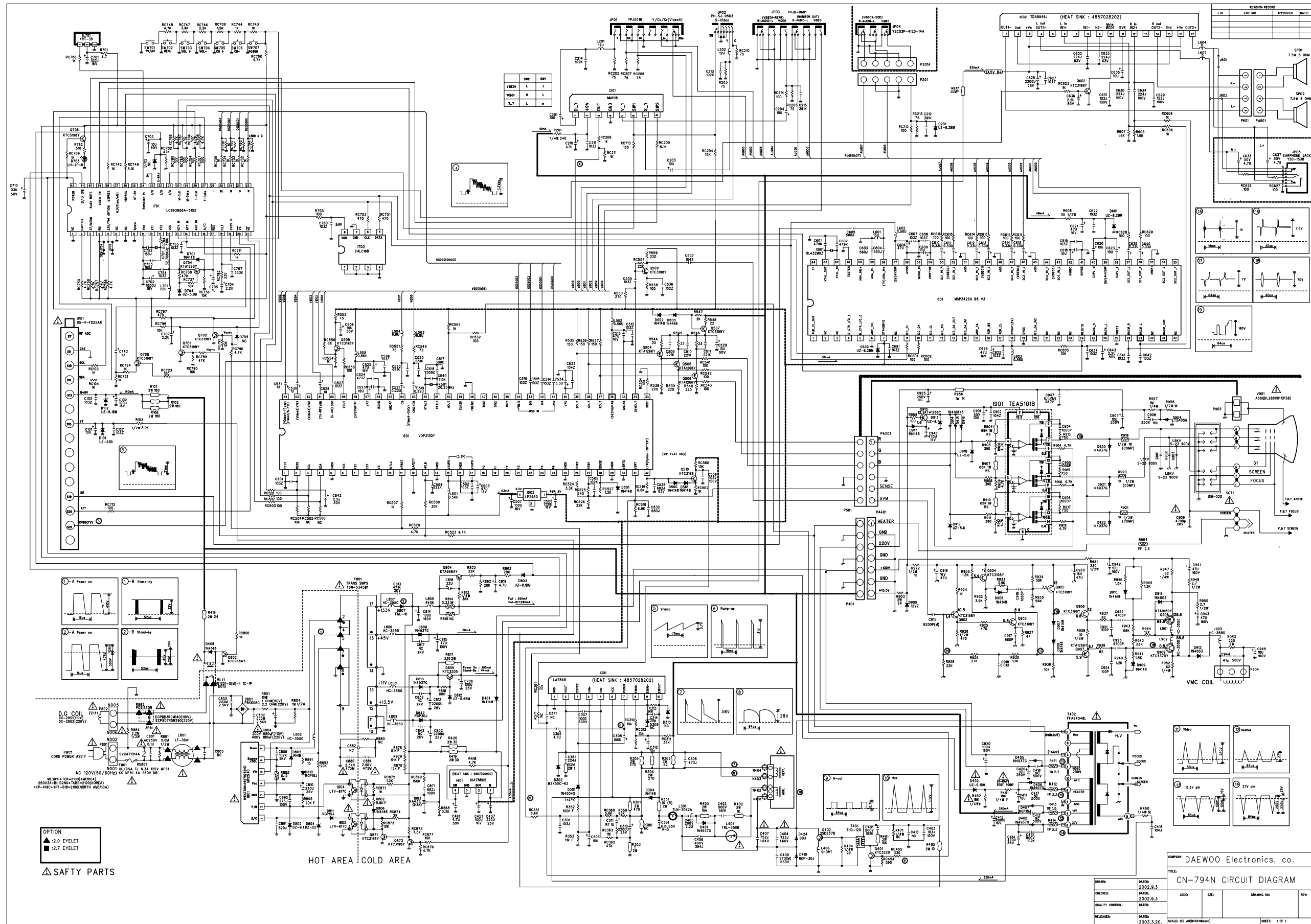

EXPLODE VIEW

DTQ-29U1SC

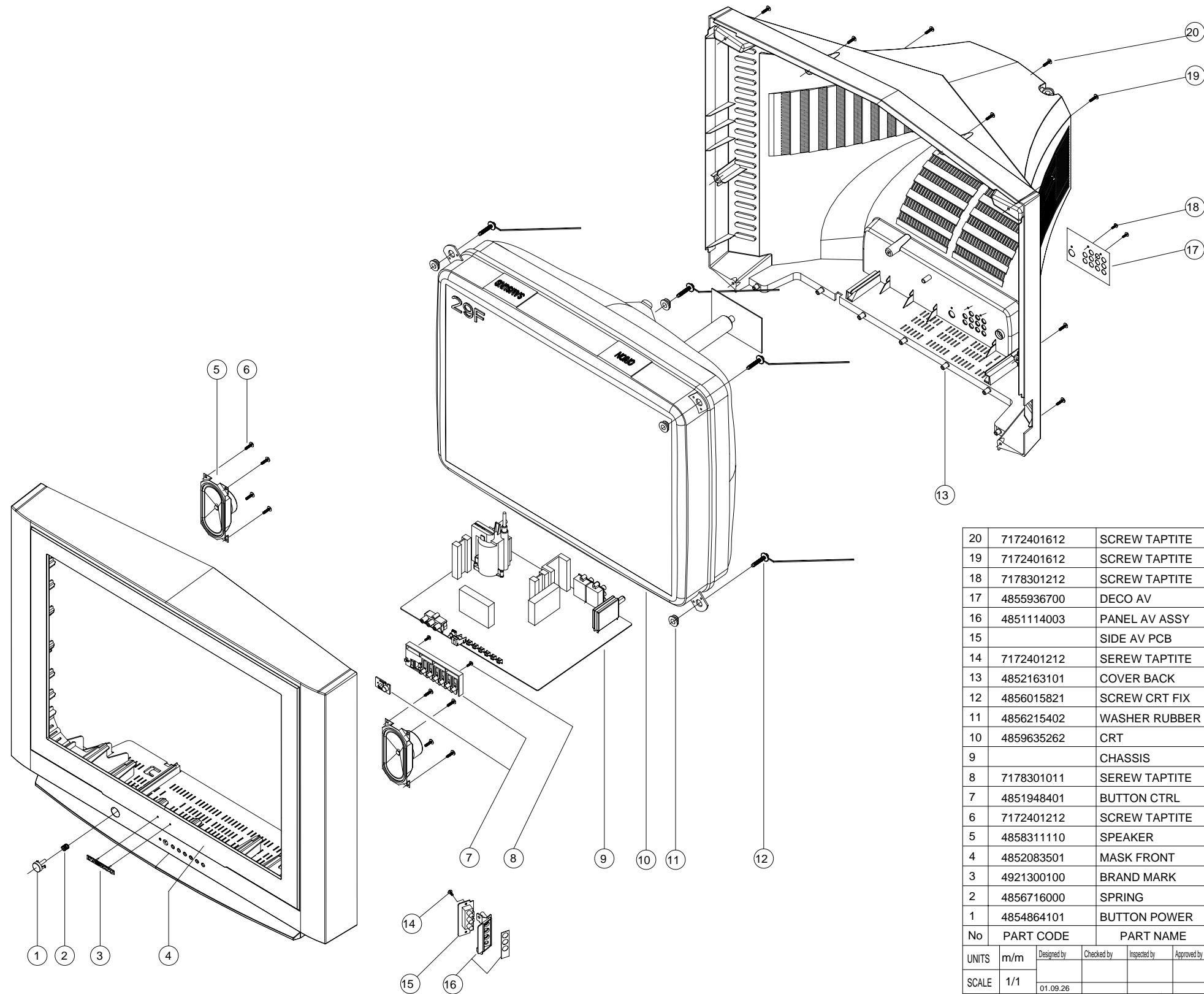

20	7172401612	SCREW TAPTITE	8	TT2 TRS 4X16 MFZN BK	
19	7172401612	SCREW TAPTITE	1	TT2 TRS 4X16 MFZN BK	
18	7178301212	SCREW TAPTITE	2	TT2 WAS 3X12 MFZN BK	
17	4855936700	DECO AV	1	PVC T0.25	
16	4851114003	PANEL AV ASSY	1	2326802+5934301	
15		SIDE AV PCB	1	CN-321	
14	7172401212	SEREW TAPTITE	1	TT2 TRS 4X12 MFZN BK	
13	4852163101	COVER BACK	1	HIPS GY	
12	4856015821	SCREW CRT FIX	4	SWRM+SK5 L=35	
11	4856215402	WASHER RUBBER	4	CR T2.0	
10	4859635262	CRT	1	29"F	
9		CHASSIS	1	CN-793F	
8	7178301011	SEREW TAPTITE	2	TT2 WAS 3X10 MFZN	
7	4851948401	BUTTON CTRL	1	4955101+5549200	
6	7172401212	SCREW TAPTITE	8	TT2 TRS 4X12 MFZN BK	
5	4858311110	SPEAKER	2	12W 8 OHM SP-58126F	
4	4852083501	MASK FRONT	1	HIPS GY	
3	4921300100	BRAND MARK	1	A1	
2	4856716000	SPRING	1	SWPA PIE0.5	
1	4854864101	BUTTON POWER	1	HIPS GY	
No	PART CODE	PART NAME	Q'ty	MATERIAL	REMARKS

UNITS	m/m	Designed by	Checked by	Inspected by	Approved by	PART NAME DEVELOPMENT DWG	
SCALE	1/1	01.09.26					
DAEWOO Electronics Corp. Mechanical Design Team, TV Research Center		MODEL	DTQ-29U1	D/N	485009KR		
		REFERENCE					

EXPLODE VIEW

DTQ-29U5SC

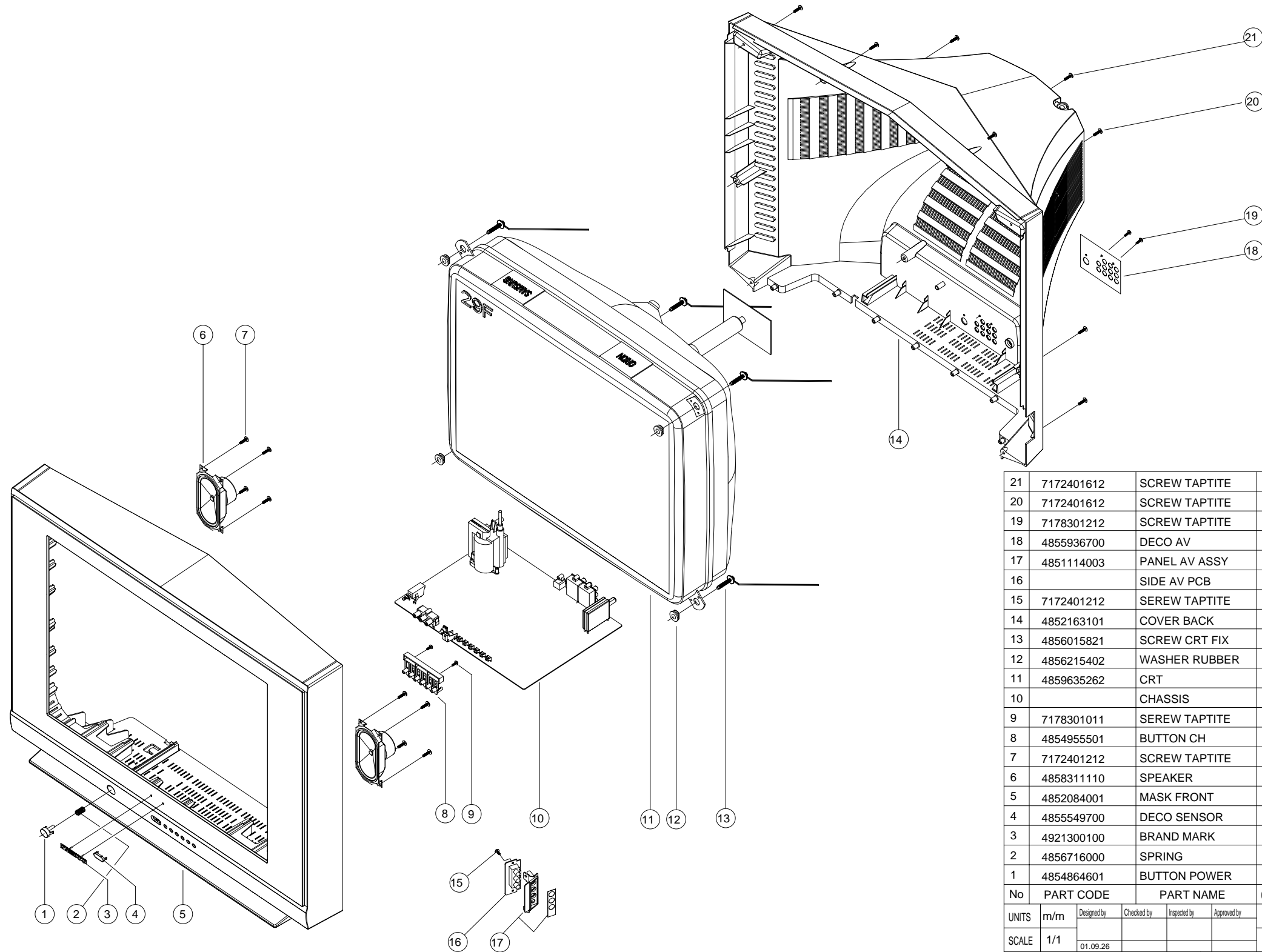

21	7172401612	SCREW TAPTITE	8	TT2 TRS 4X16 MFZN BK	
20	7172401612	SCREW TAPTITE	1	TT2 TRS 4X16 MFZN BK	
19	7178301212	SCREW TAPTITE	2	TT2 WAS 3X12 MFZN BK	
18	4855936700	DECO AV	1	PVC T0.25	
17	4851114003	PANEL AV ASSY	1	2326802+5934301	
16		SIDE AV PCB	1	CN-321	
15	7172401212	SEREW TAPTITE	1	TT2 TRS 4X12 MFZN BK	
14	4852163101	COVER BACK	1	HIPS GY	
13	4856015821	SCREW CRT FIX	4	SWRM+SK5 L=35	
12	4856215402	WASHER RUBBER	4	CR T2.0	
11	4859635262	CRT	1	29"F	
10		CHASSIS	1	CN-794F	
9	7178301011	SEREW TAPTITE	2	TT2 WAS 3X10 MFZN	
8	4854955501	BUTTON CH	1	ABS GY	
7	7172401212	SCREW TAPTITE	8	TT2 TRS 4X12 MFZN BK	
6	4858311110	SPEAKER	2	12W 8 OHM SP-58126F	
5	4852084001	MASK FRONT	1	HIPS GY	
4	4855549700	DECO SENSOR	1	PC SMOG	
3	4921300100	BRAND MARK	1	A1	
2	4856716000	SPRING	1	SWPA PIE0.5	
1	4854864601	BUTTON POWER	1	HIPS GY	
No	PART CODE	PART NAME	Q'ty	MATERIAL	REMARKS

UNITS	m/m	Designed by	Checked by	Inspected by	Approved by	PART NAME DEVELOPMENT DWG	
SCALE	1/1	01.09.26					
DAEWOO Electronics Corp. Mechanical Design Team, TV Research Center		MODEL	DTQ-29U5	D/N	485009KU		
		REFERENCE					

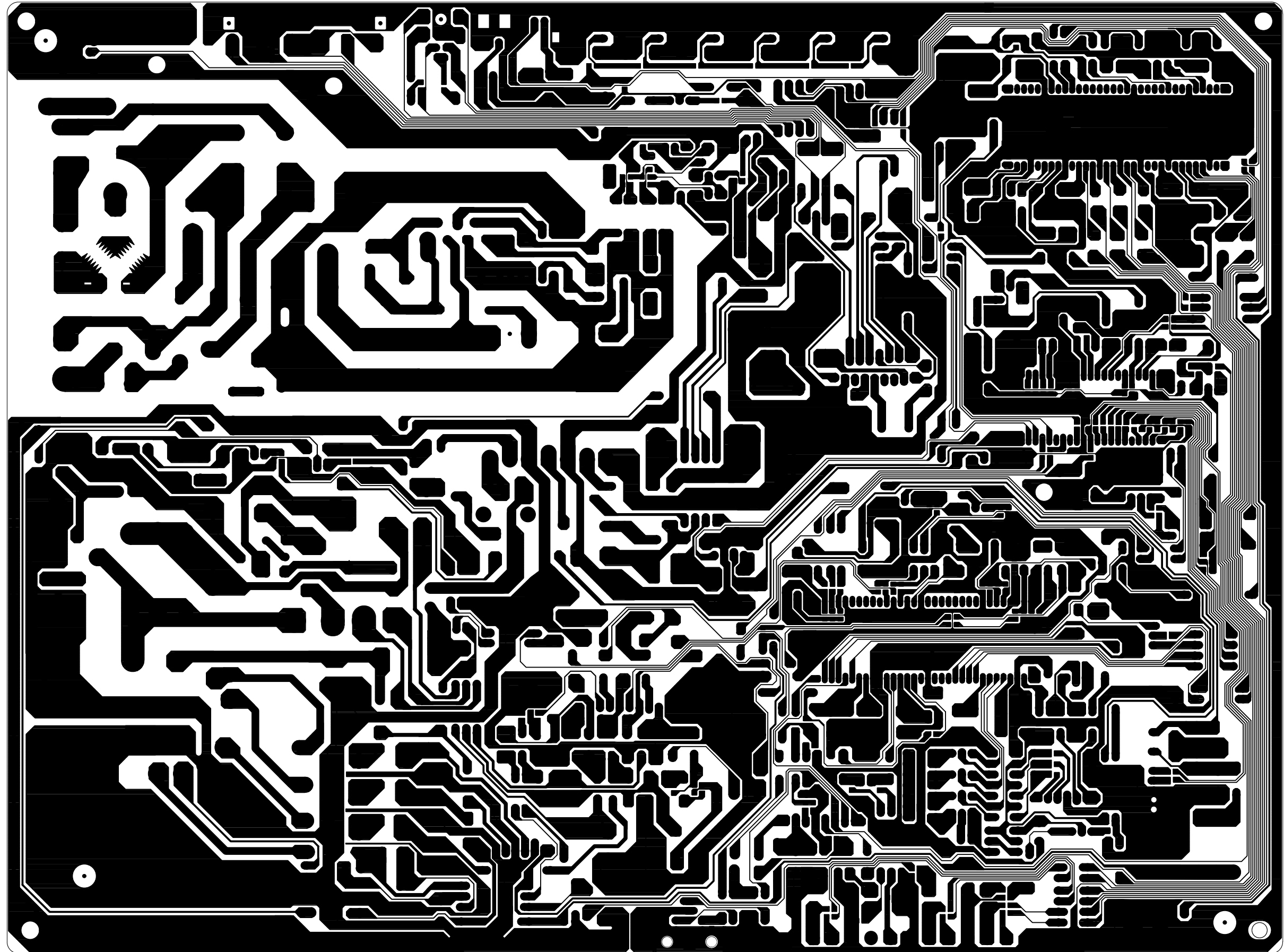

PRINTED CIRCUIT BOARD (CN-794N/MAIN / Silkscreen Bottom)

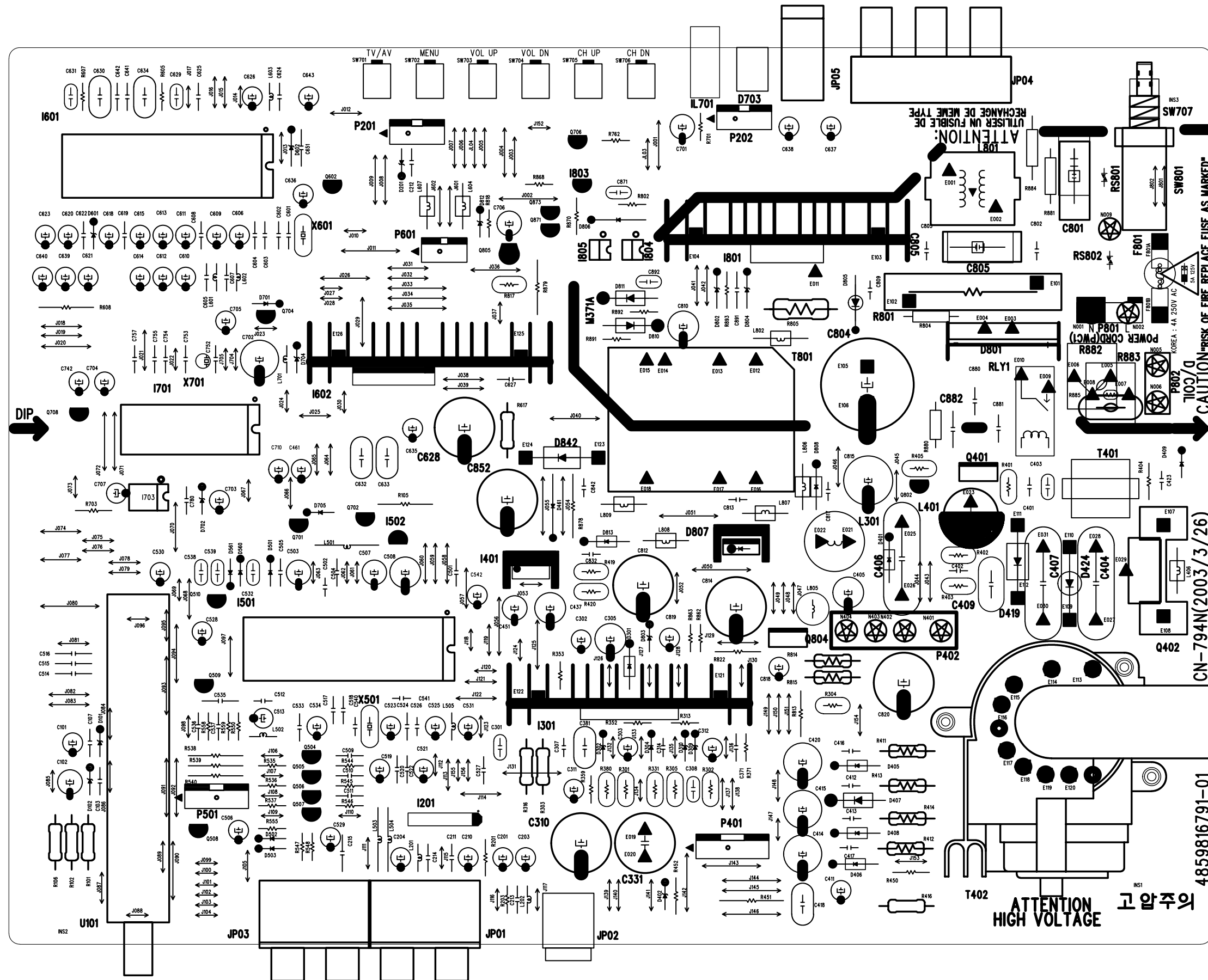

PRINTED CIRCUIT BOARD (CN-794N/MAIN / Silkscreen Top)

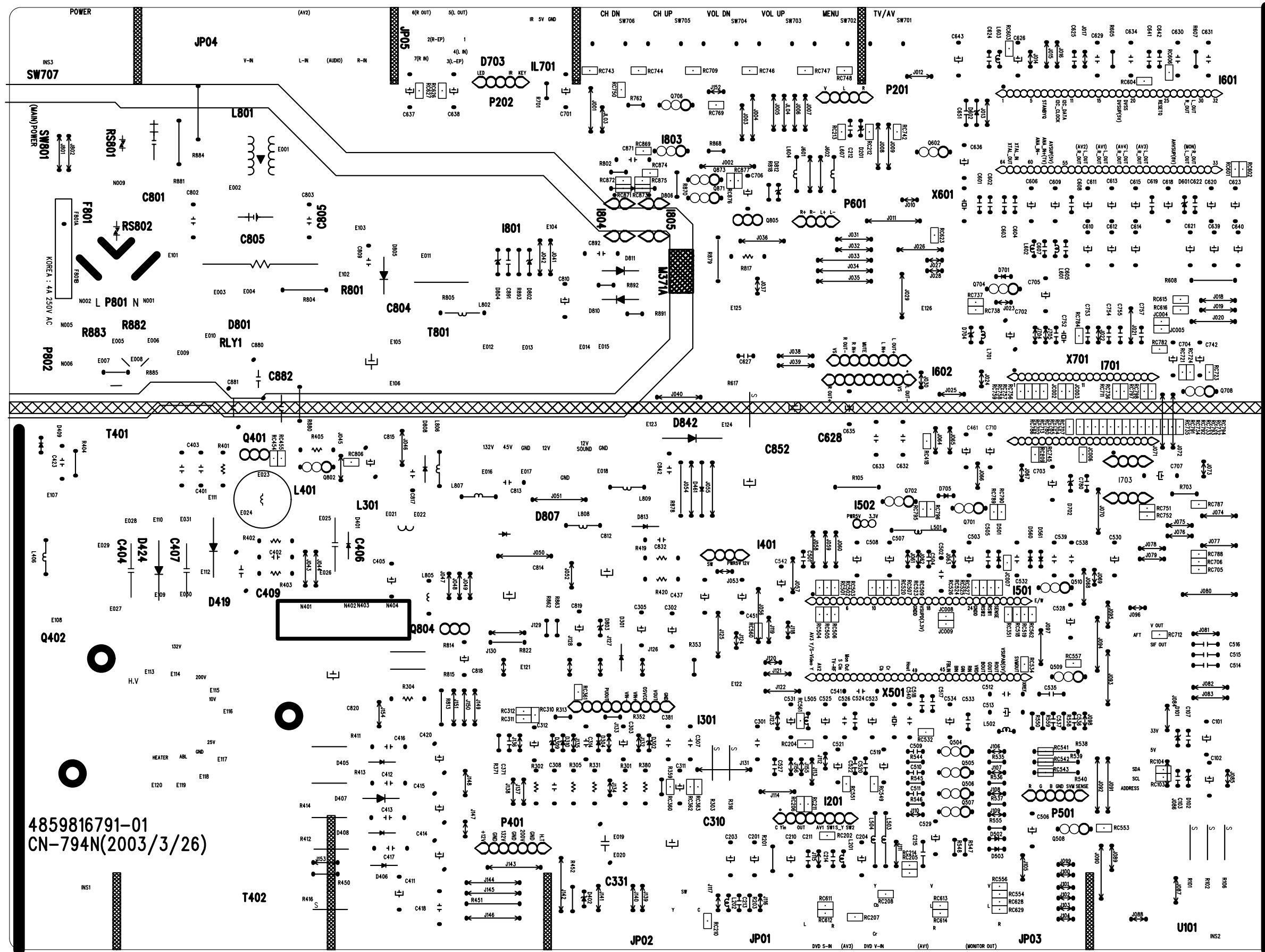

PRINTED CIRCUIT BOARD (CN-794N/MAIN / Drill Drawing)

SIZE	QTY	SYM	PLTD
5.7	1	I	PLTD
2	33	J	PLTD
4	9	K	PLTD
2.1	1	L	PLTD
0.7	172	M	PLTD
1.2	62	N	PLTD
1.1	70	O	PLTD
2.5	9	P	PLTD
2.4	2	Q	PLTD
1.3	16	R	PLTD
1.7	6	S	PLTD
1.5	4	T	PLTD
0.8	14	U	PLTD
1	1021	V	PLTD
0.9	34	W	PLTD
2.7	36	X	PLTD
3.4	3	Y	PLTD
1.6	14	Z	PLTD

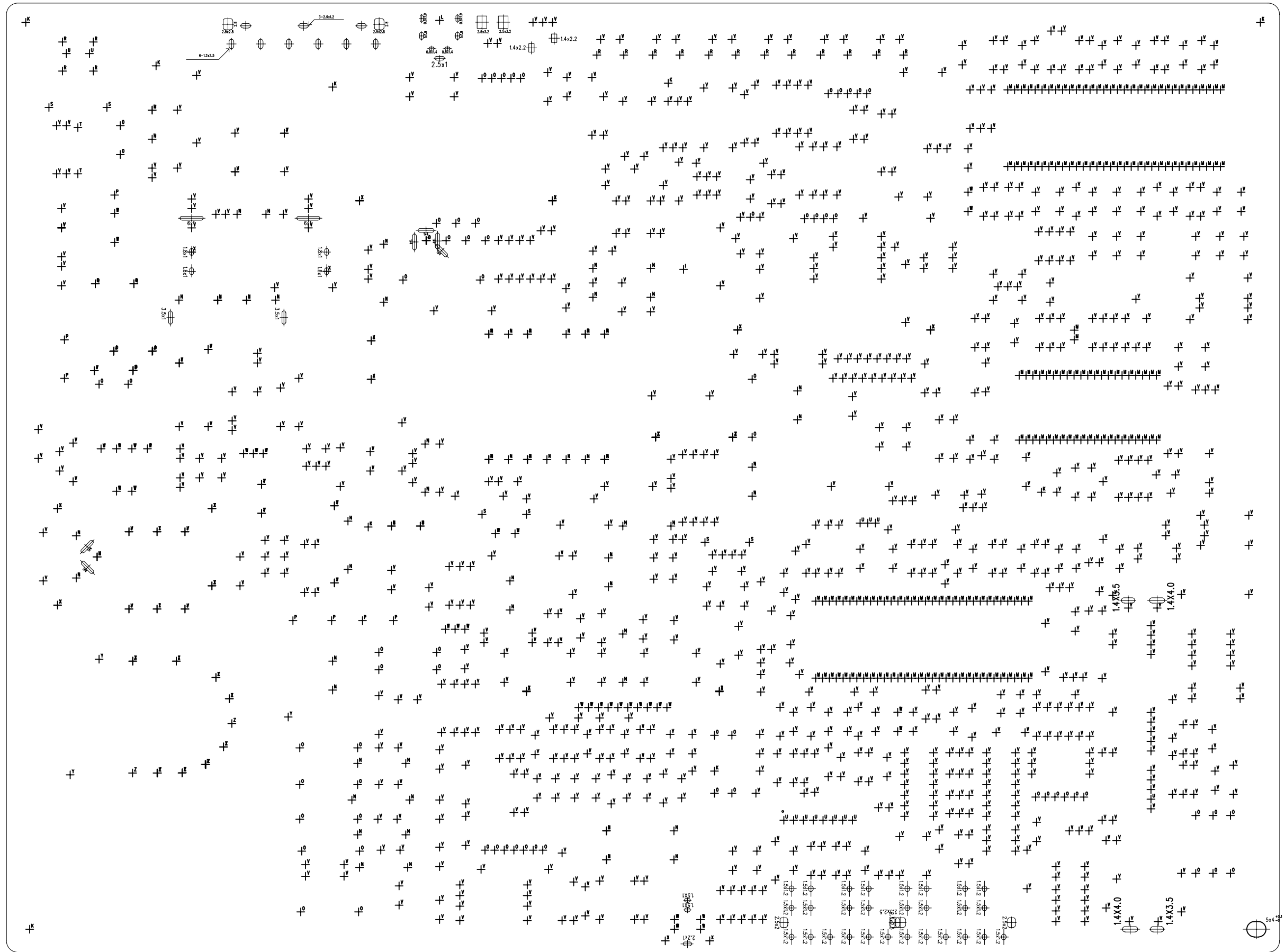

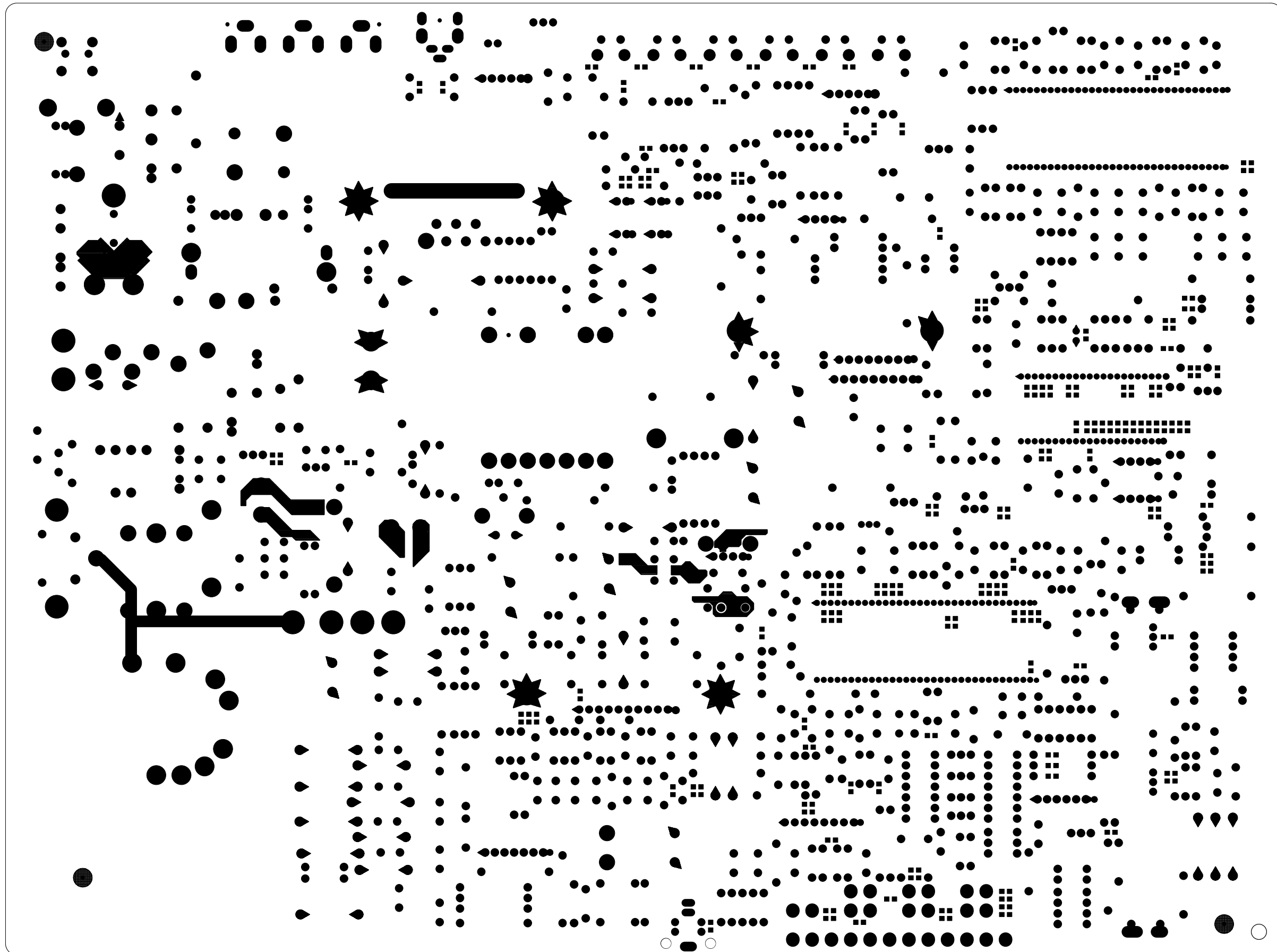

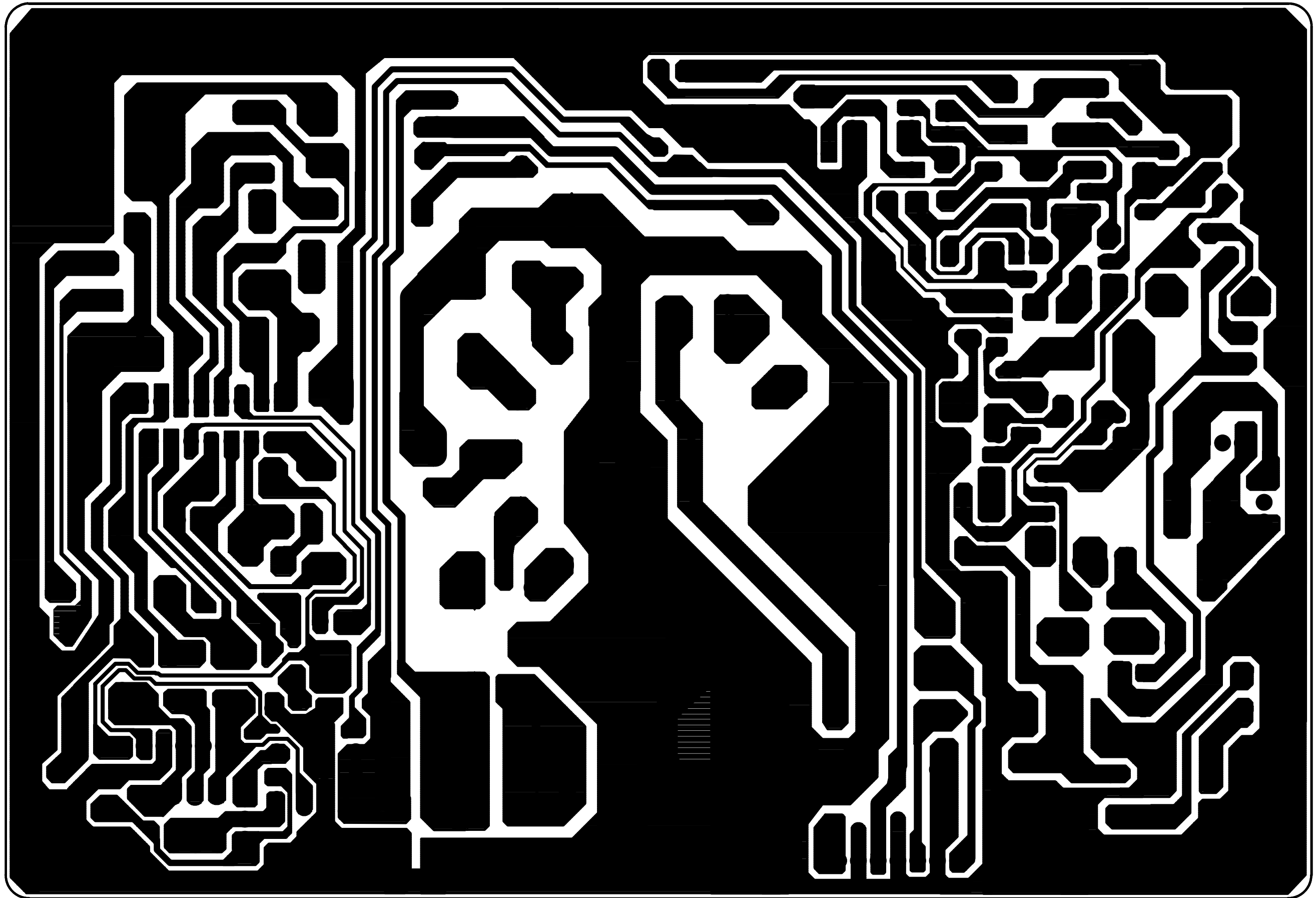

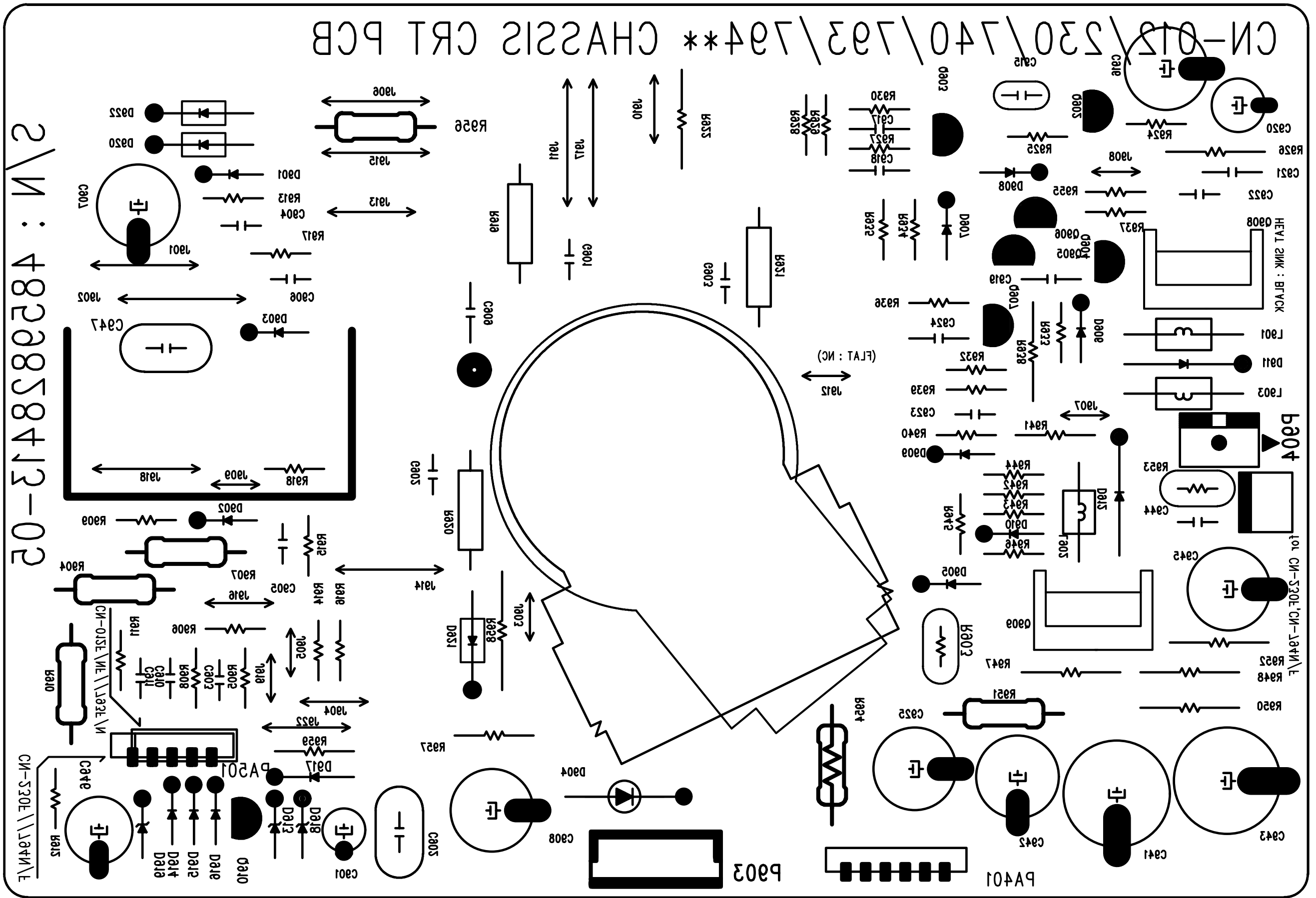

CN-012/230/740/793/794** CHASSIS CRT PCB

S/N : 4859828413-05

5PIN:CN-012F/NF,CN-793F/N
6PIN:CN-230F,CN-794N/F

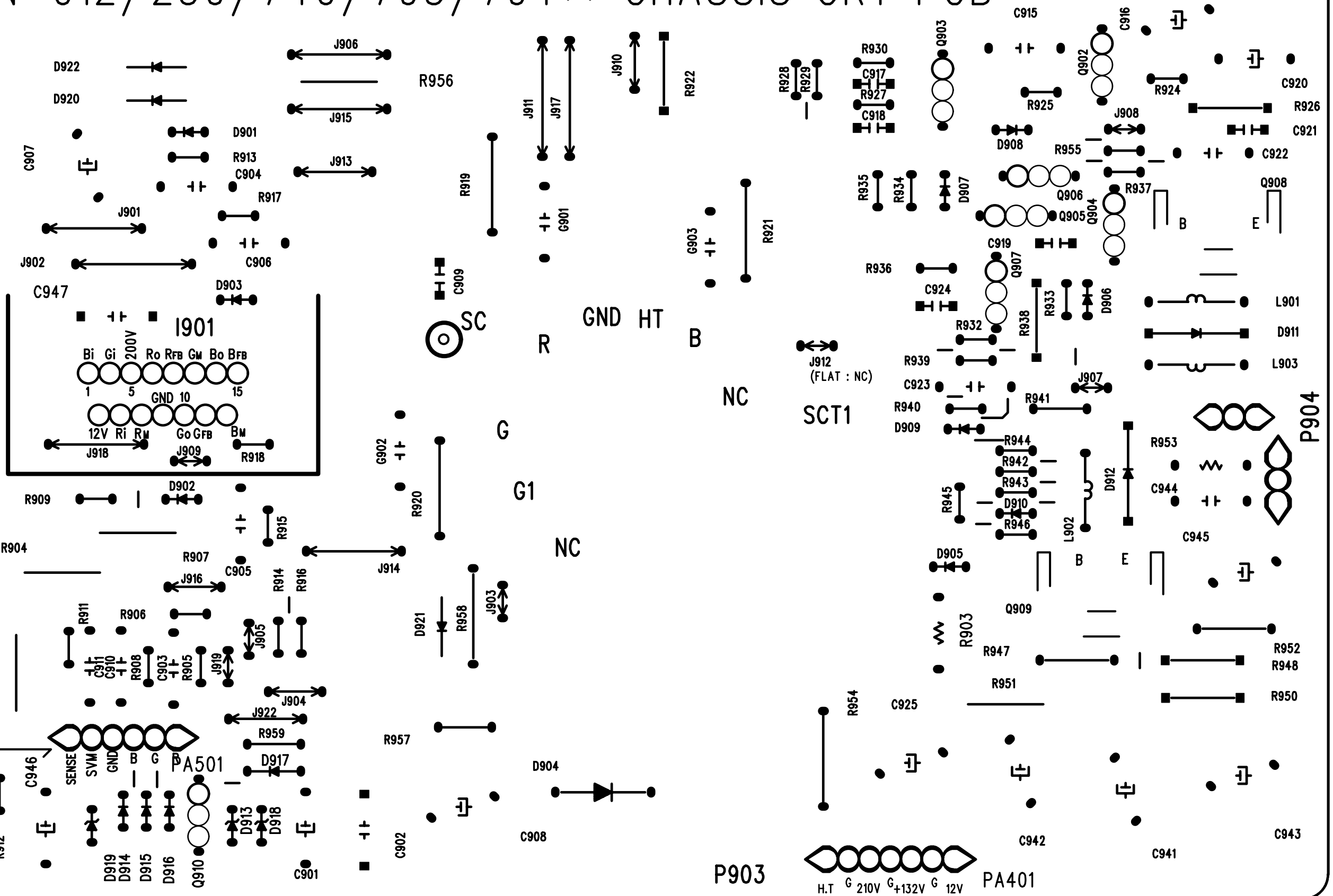

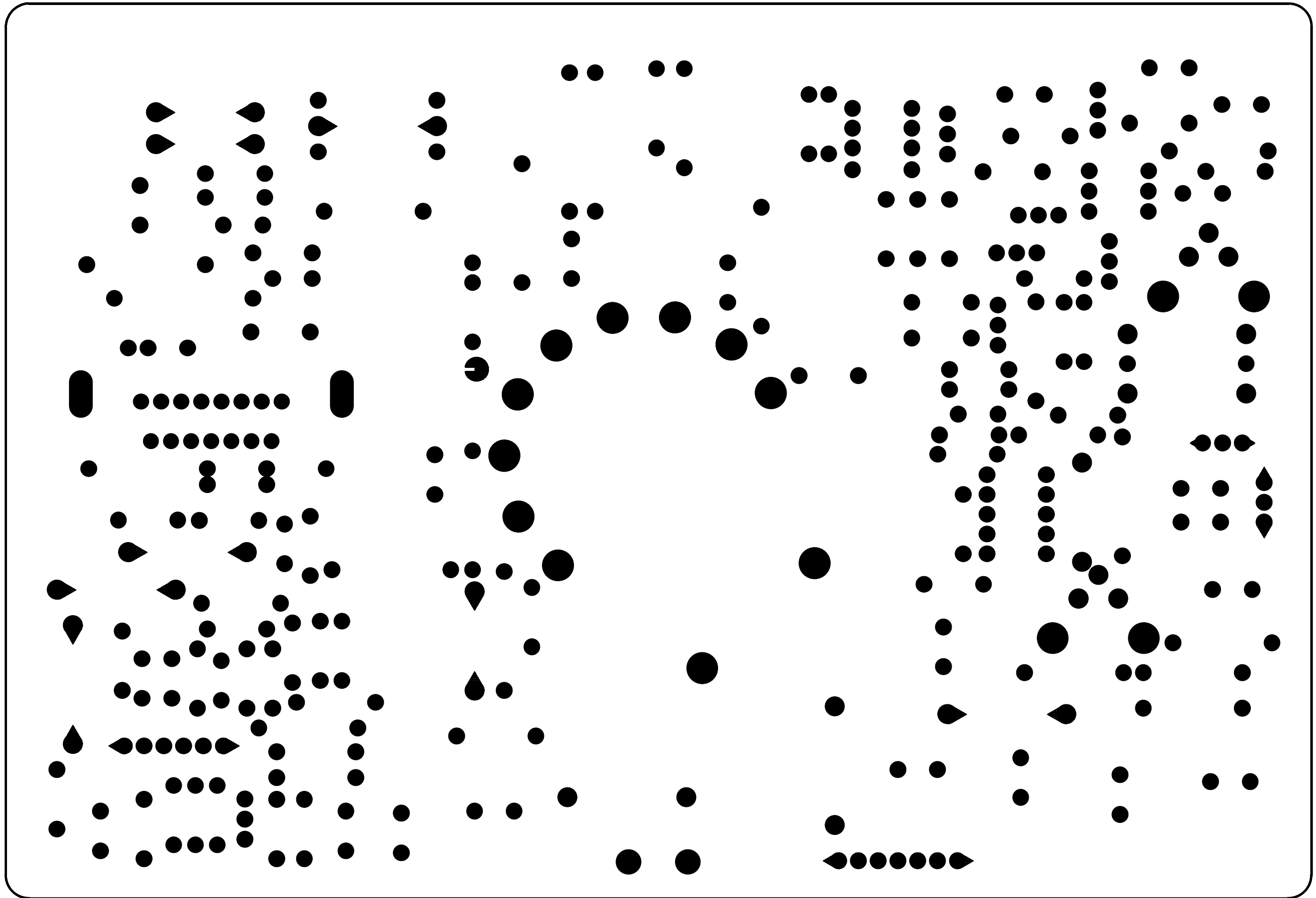

1. Pin Congiguration

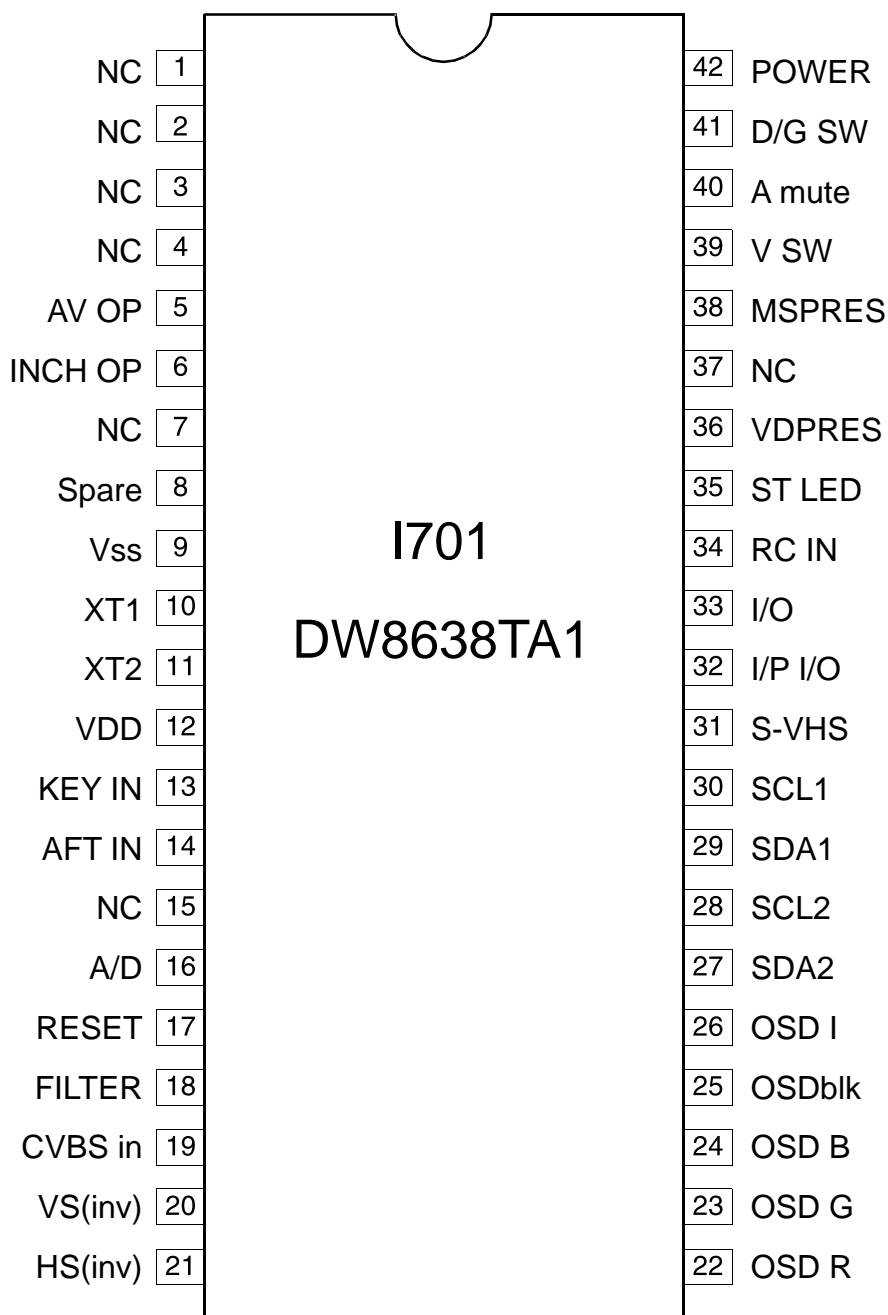

*SCL1/SDA1 -> VDP/MSP/EEPROM, SCL2/SDA2 -> TUNER.

2. Pin Description

PIN	PIN NAME	DESCRIPTION	DEF	ACT	I/O	PUD	STB
1	P10	NC				D	
2	P11	NC	-			D	
3	P12	NC	-			D	
4	P13	NC	-			D	-
5	P14	AV(CVBS in) OPTION H : AV1~AV2, CVI ; L : AV1~AV3, CVI	-	H	I	U	-
6	P15	INCH OPTION				D	
7	P16	NC				D	
8	P17	NC(Spare)					
9	VSS	GND					
10	XT1	Crystal INPUT			I		
11	XT2	Crystal OUTPUT			O		
12	VDD	Supply Voltage(+5V)			-		
13	P84/AN4	Key INPUT	-	-	I	U	H
14	P85/AN5	AFT Signal INPUT	-	H	I	-	L
15	P86/AN6	NC	-		I	-	
16	P87/AN7	NC	-		I	-	
17	RES(inv)	Reset	-	L	I	-	H
18	FILT	MCU PLL Filter					
19	CVBSIN	Composite Video (Closed Caption)		H	I		
20	VS(inv)	Vertical Sync		L	I	U	H
21	HS(inv)	Horizontal Sync		L	I	U	H
22	R	OSD RED Signal OUTPUT		H	O		
23	G	OSD GREEN Signal OUTPUT		H	O		
24	B	OSD BLUE Signal OUTPUT		H	O		
25	BL	OSD BLANKING Signal OUTPUT		H	O		
26	I	OSD Intensity					
27	SDA0	Tuner serial data OUTPUT		H	O	U	
28	SCLK0	Tuner clock OUTPUT		H	O	U	
29	SDA1	IC serial data INPUT/OUTPUT		H	I/O	U	
30	SCLK1	IC clock OUTPUT		H	O	U	
31	S-VHS	S-JACK 'H' input - DEFAULT 'H' *P70	L	H	I	-	
32	P71	NC			I		
33	P72	NC					
34	P73	Remote control Signal INPUT		L	I		H
35	P00	NC					
36	P01	VDP3130Y reset OUTPUT	L	H	O	-	L
37	P02	NC				-	
38	P03	MSP3420G reset OUTPUT	L	H	O	-	L
39	P04	Video SW OUTPUT : ONLY AV4 'H'	L	H	O	-	L
40	P05	Audio mute OUTPUT	L	H	O	-	L
41	P06	Degaussing Coil SW OUTPUT	L	H	O	-	L
42	P07	Stand-by Power SW OUTPUT	L	H	O	-	H

NOTE : DEF(default), ACT(Active), I/O(Input/Output), PUD(Pull-up/-down), STB(Stand-by)

3. Pin Congration

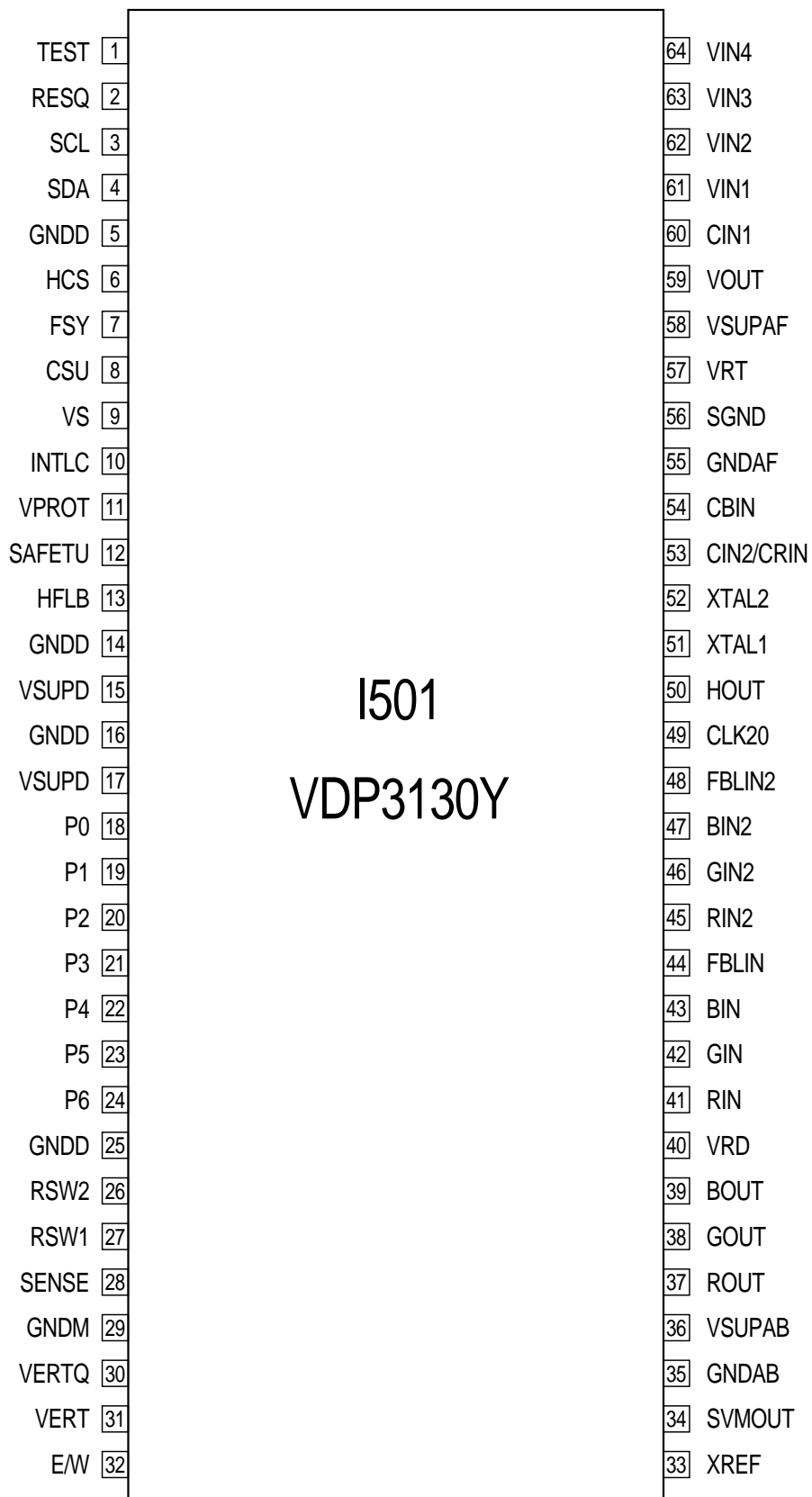

4. Pin Description

Pin No.	Pin Name	Type	Short Description
1	TEST	IN	Test Input
2	RESQ	IN	Reset Input
3	SCL	IN/OUT	I2C Bus Clock
4	SDA	IN/OUT	I2C Bus Data
5	GNDD	SUPPLY	Digital Ground
6	HCS	IN	Half Contrast Switch Input
7	FSY	OUT	Front Sync Out
8	CSY	OUT	Composite Sync Output
9	VS	OUT	Vertical Sync Output
10	INTLC	OUT	Interlace Control Output
11	VPROT	IN	Vertical Protection Input
12	SAFETY	IN	Safety Input
13	HFLB	IN	Horizontal Flyback Input
14	GNDD	SUPPLY	Digital Ground
15	VSUPD	SUPPLY	Digital Supply Voltage(3.3v)
16	GNDD	SUPPLY	Digital Ground
17	VSUPD	SUPPLY	Digital Supply Voltage(3.3v)
18	P0	IN/OUT	Port 1, Bit 0
19	P1	IN/OUT	Port 1, Bit 1
20	P2	IN/OUT	Port 1, Bit 2
21	P3	IN/OUT	Port 1, Bit 3
22	P4	IN/OUT	Port 1, Bit 4
23	P5	IN/OUT	Port 1, Bit 5
24	P6	IN/OUT	Port 1, Bit 6
25	GNDD	SUPPLY	Digital Ground
26	RSW2	OUT	Range Switch 2 for Measurement ADC
27	RSW1	OUT	Range Switch 1 for Measurement ADC
28	SENSE	IN	Sense ADC Input
29	GNDM	SUPPLY	Ground, MADC Input
30	VERTQ	OUT	Inverted Vertical Sawtooth Output
31	VERT	OUT	Vertical Sawtooth Output
32	E/W	OUT	Vertical Parabola Output
33	XREF	IN	Reference Input for RGB DACs
34	SVMOUT	OUT	Analog Scan Velocity Modulation Output
35	GNDAB	SUPPLY	Analog Ground Backend
36	VSUPAB	SUPPLY	Analog Supply Voltage(5.0v)Backend
37	ROUT	OUT	Analog Red Output
38	GOUT	OUT	Analog Green Output
39	BOUT	OUT	Analog Blue Output
40	VRD	IN	DAC Reference
41	RIN	IN	Analog Red Input
42	GIN	IN	Analog Green Input
43	BIN	IN	Analog Blue Input
44	FBLIN	IN	Fast Blank Input

Pin No.	Pin Name	Type	Short Description
45	RIN2	IN	Analog Red Input2
46	GIN2	IN	Analog Green Input2
47	BIN2	IN	Analog Blue Input2
48	FBLIN2	IN	Fast Blank Input
49	CLK20	OUT	20.25MHz System Clock Output
50	HOUT	OUT	Horizontal Drive Output
51	XTAL1	IN	Analog Crystal Input
52	XTAL2	OUT	Analog Crystal Output
53	CIN2/CRIN	IN	Analog chroma2/component CR Input
54	CBIN	IN	Component CB Input
55	GNDAF	SUPPLY	Analog Ground Frontend
56	SGND	IN	Signal Ground for Analog input
57	VRT	IN	Reference Voltage Top
58	VSUPAF	SUPPLY	Analog Supply Voltage(5.0V)Frontend
59	VOUT	OUT	Analog Vodeo output
60	CIN1	IN	Analog Chroma 1 Input
61	VIN1	IN	Analog Video 1 Input
62	VIN2	IN	Analog Video 2 Input
63	VIN3	IN	Analog Video 3 Input
64	VIN4	IN	Analog Video 4 Input

(1) I801 PIN7 POWER ON

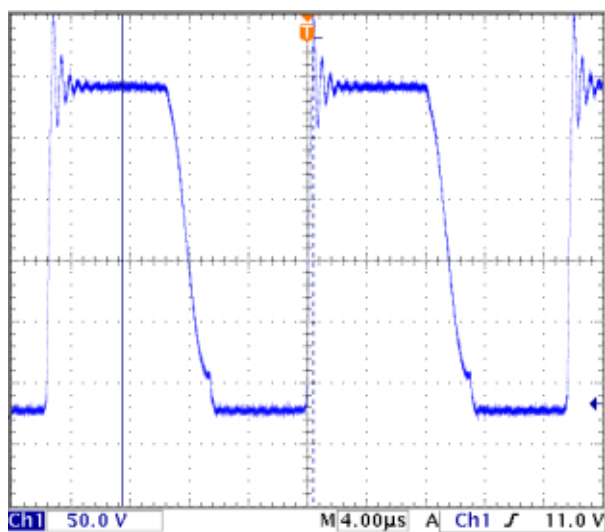

(1) I801 PIN7 STAND-BY

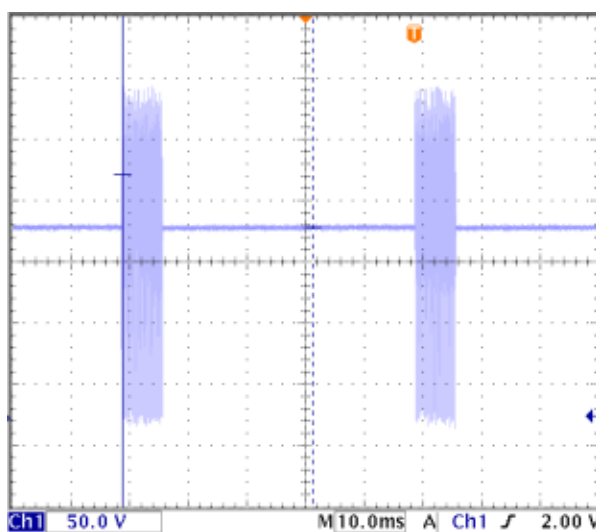

(2) T801 PIN17 POWER ON

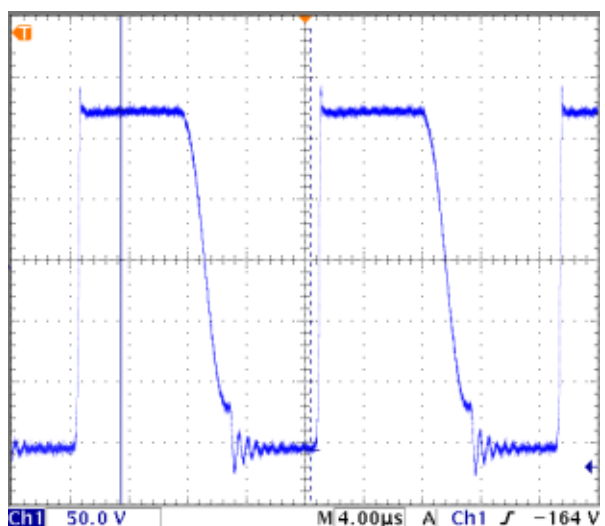

(2) T801 PIN17 STAND-BY

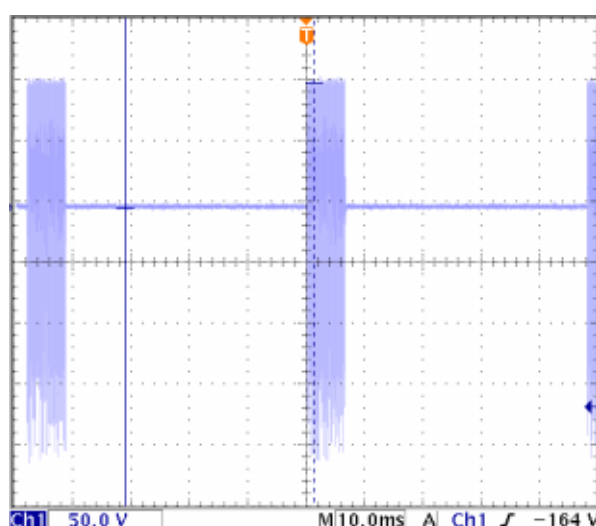

(3) I501 PIN50 HOUT



(4) T402 PIN1 HOR.OUT

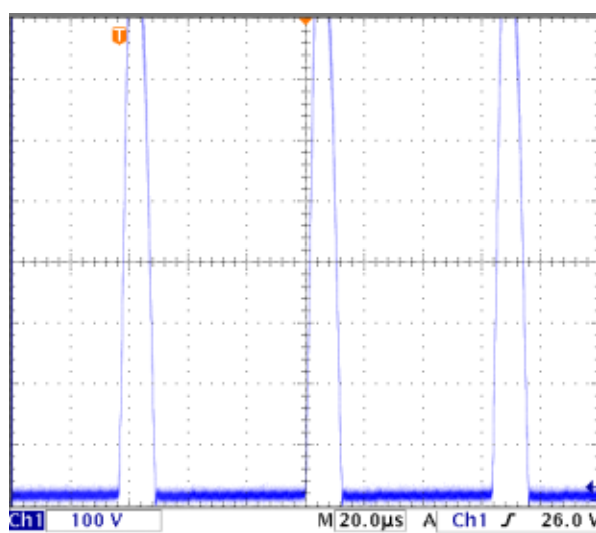

0

(5) T402 PIN3 200V LINE

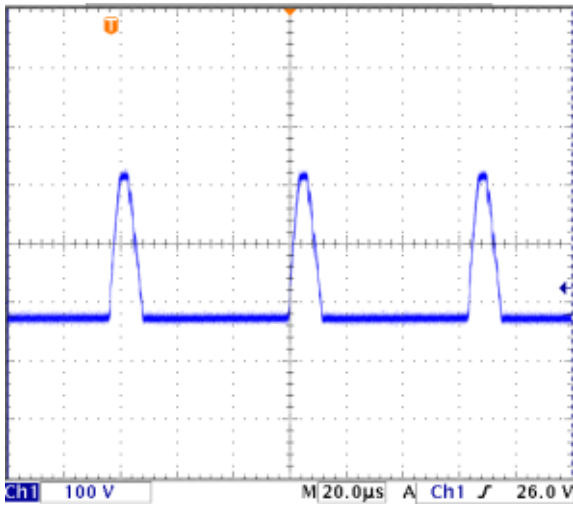

(6) T402 PIN9 HEATER LINE

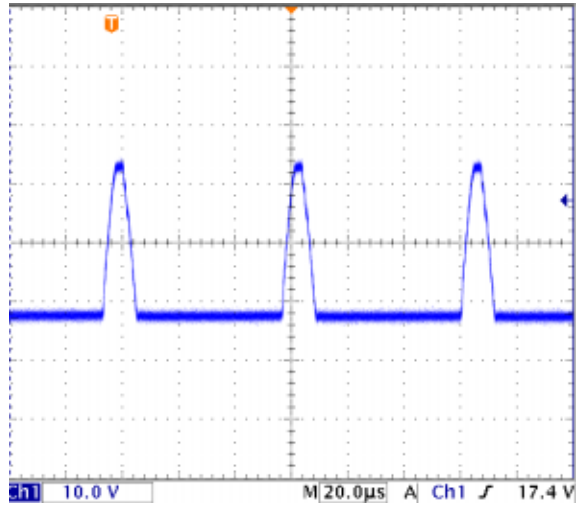

(7) T402 PIN4 12V LINE

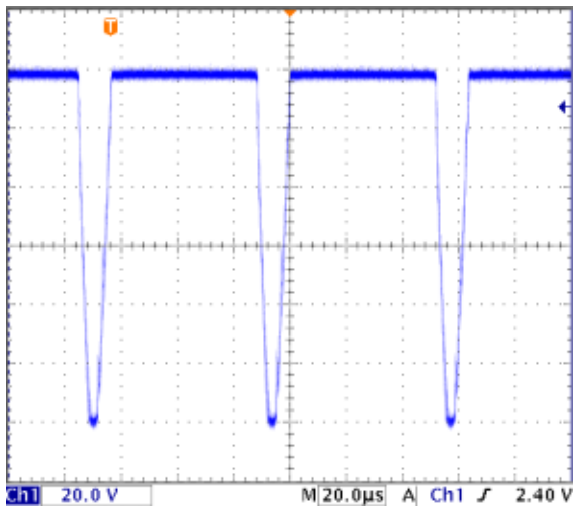

(8) T402 PIN6 27V LINE

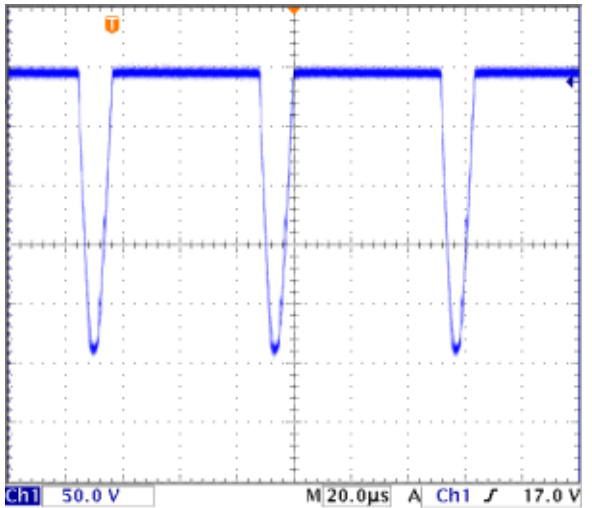

(9) I501 PIN31 VERTICAL RAMP

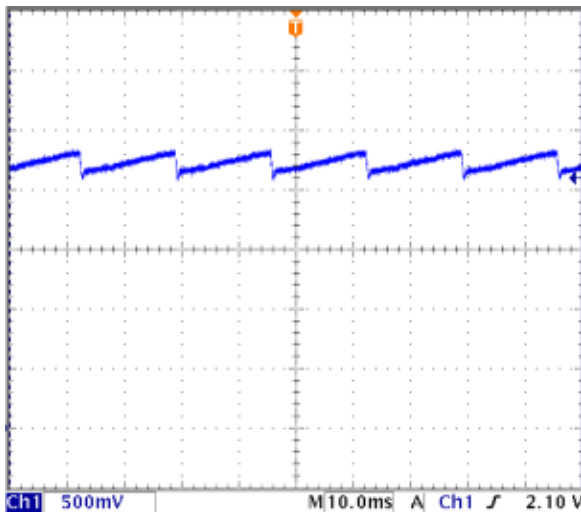

(10) I501 PIN32 E/W

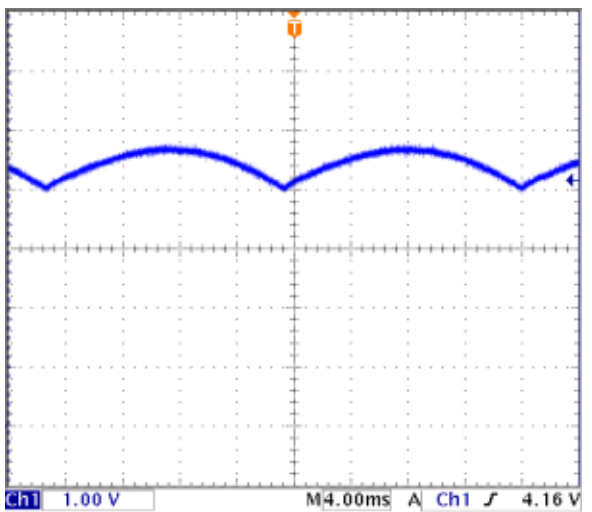

(11) CVBS (Composite Video)

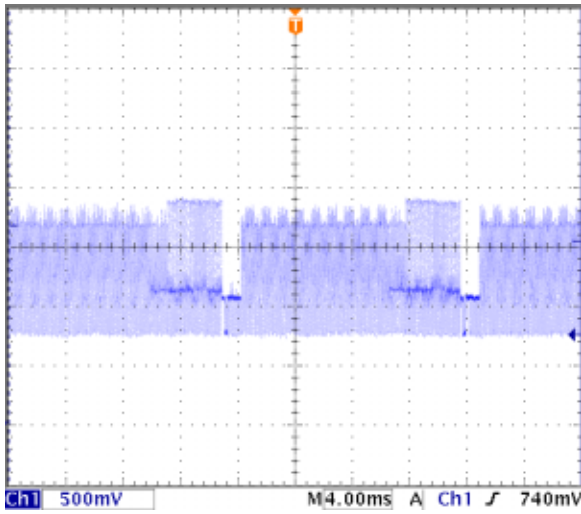

(12) I501 PIN52 VDP X-TAL

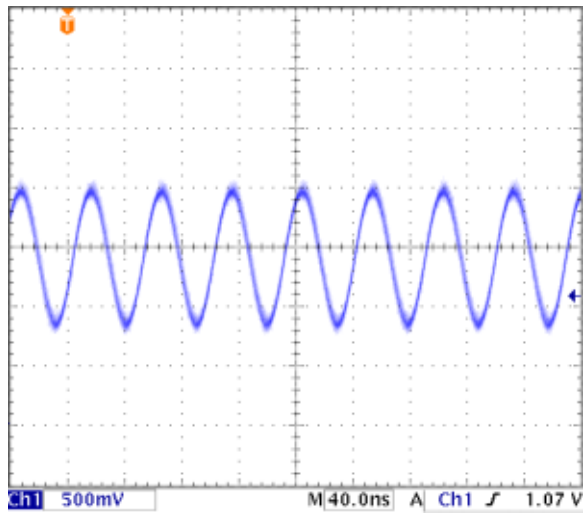

(13) I501 PIN11 VSYNC

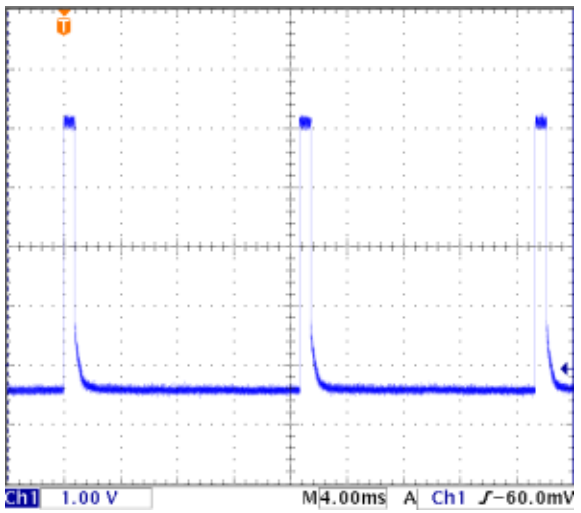

(14) SVM Q902 BASE

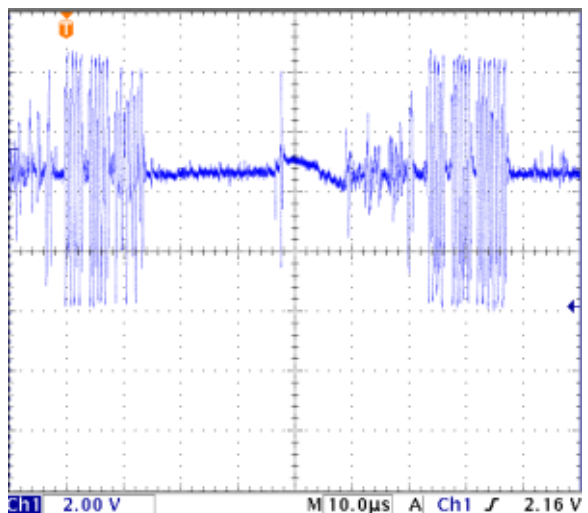

(15) SVM Q906 BASE

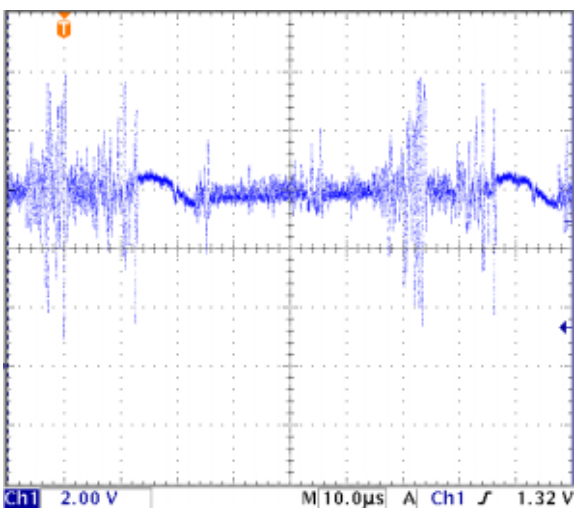

(16) SVM Q907 BASE

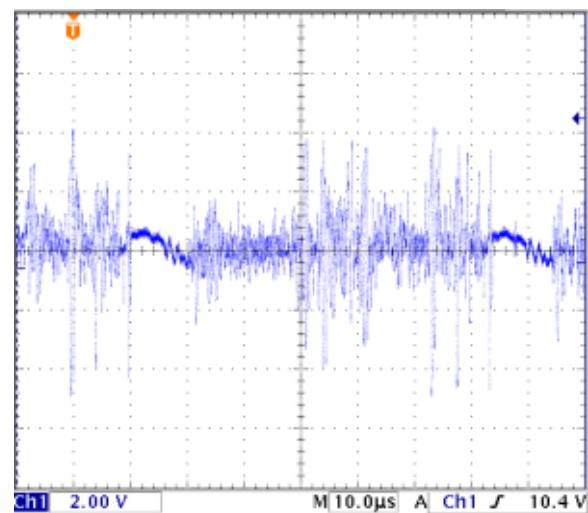

(17) SVM Q909 BASE

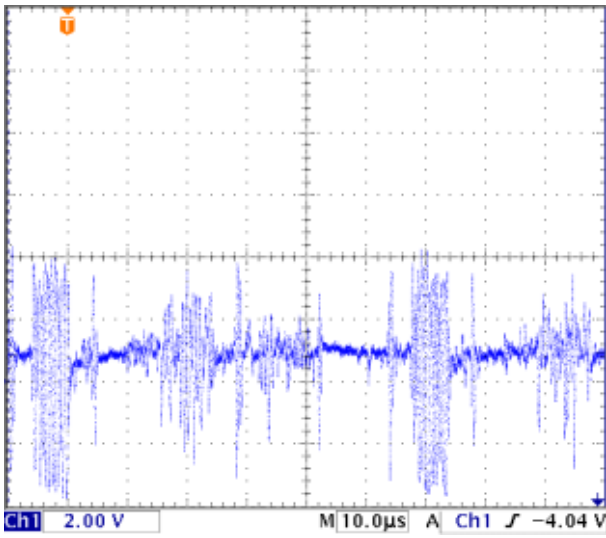

(18) I901 PIN7 ROUT

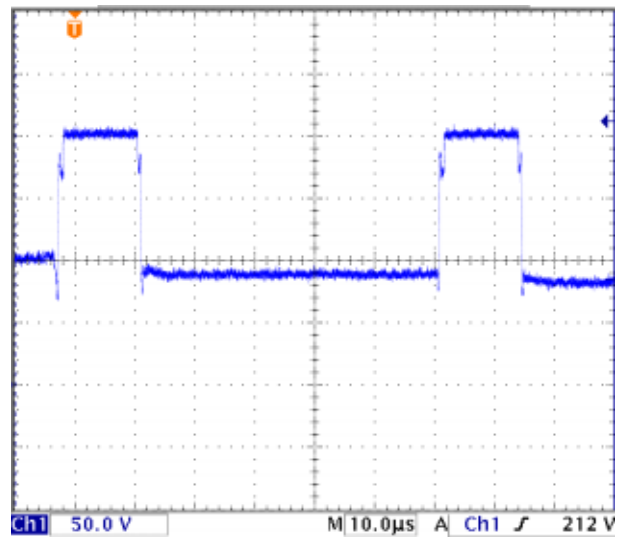

1.NO POWER

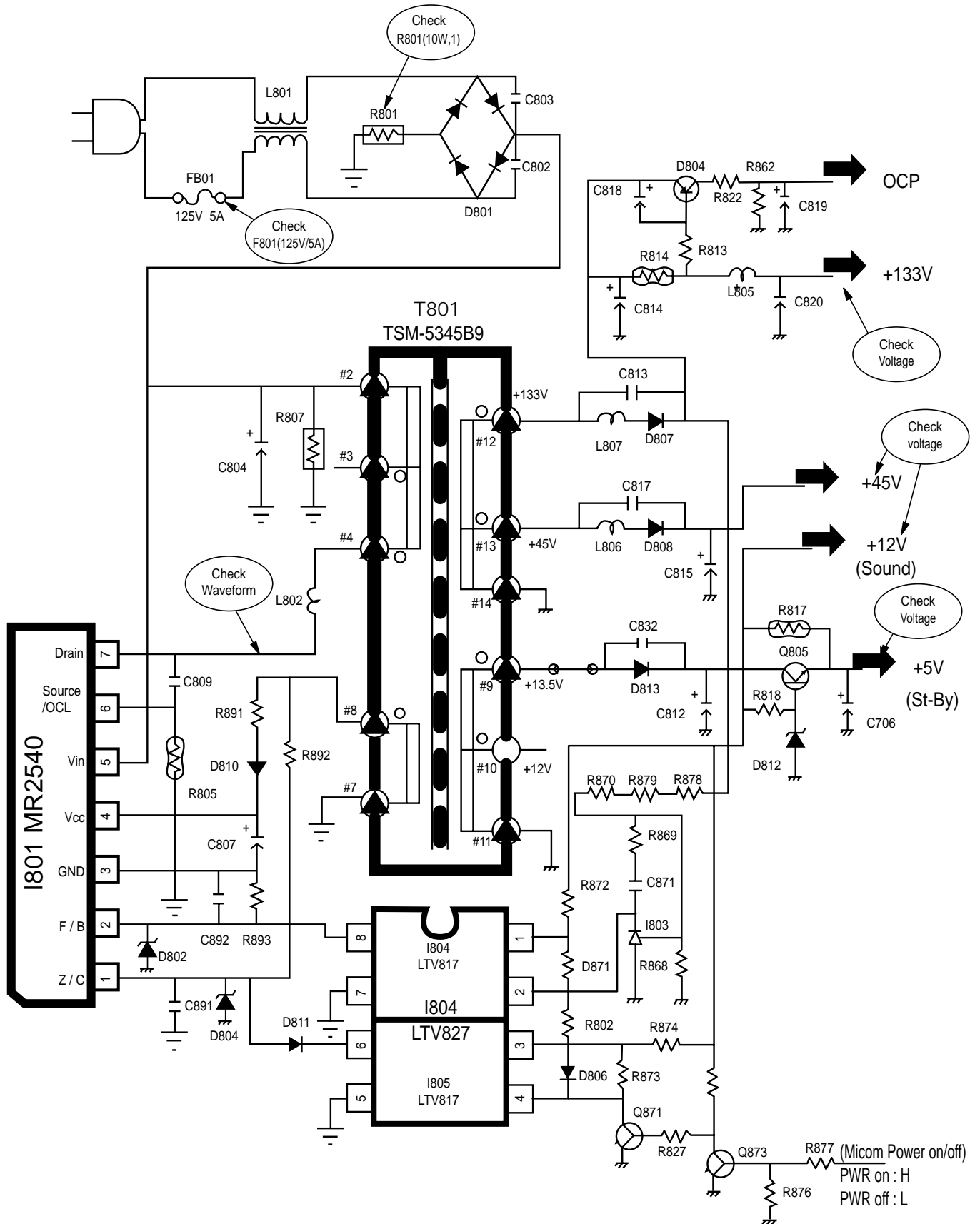

2.NO PICTURE

check the waveform of I501 #61	NG : Go to the figure (c)
	OK : Go to the figure (d)

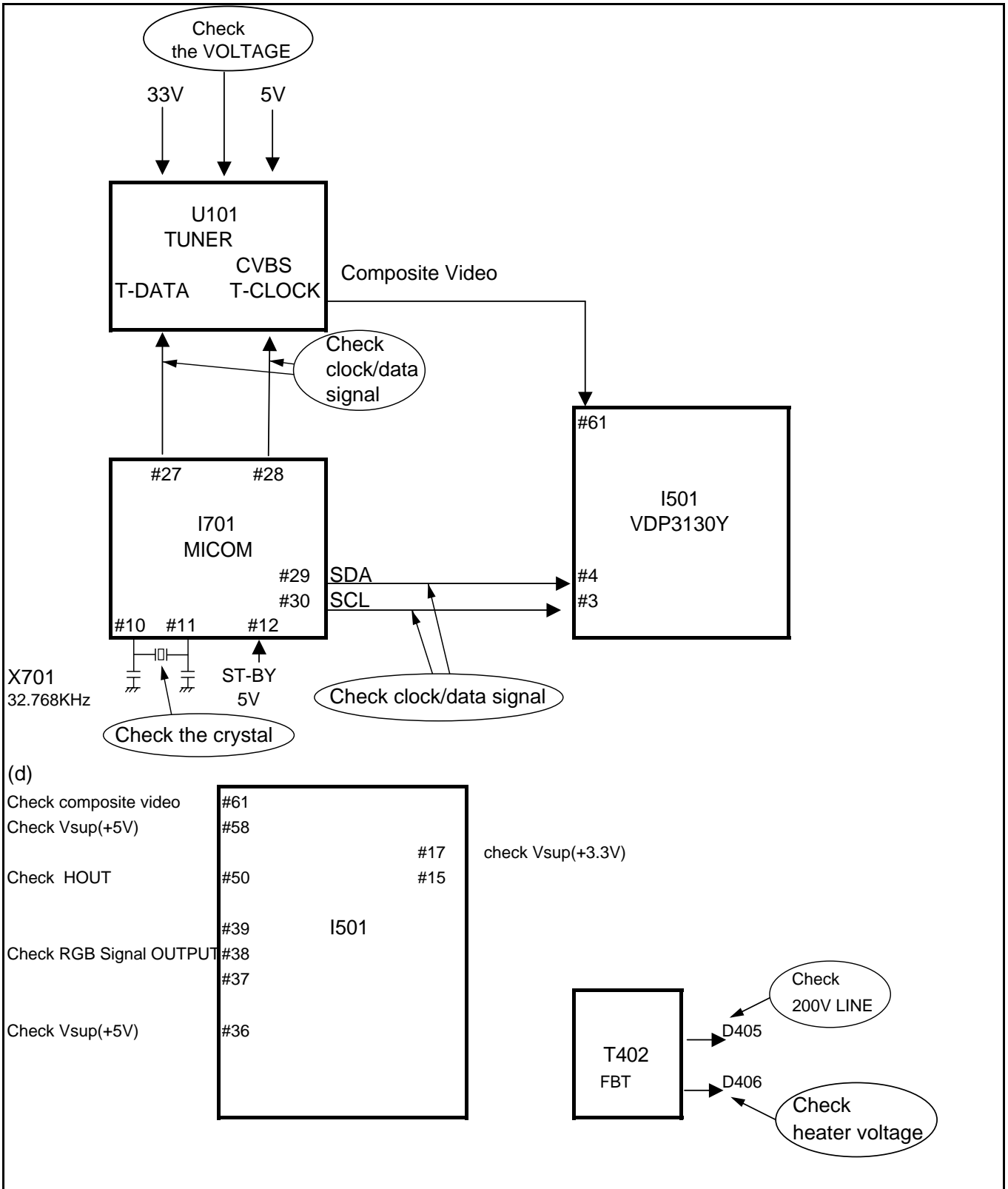

3. NO SOUND

Check MSP output data signal of I601 #28, #29	NG : Go to the figure (e)
	OK : Go to the figure (f)

(e)

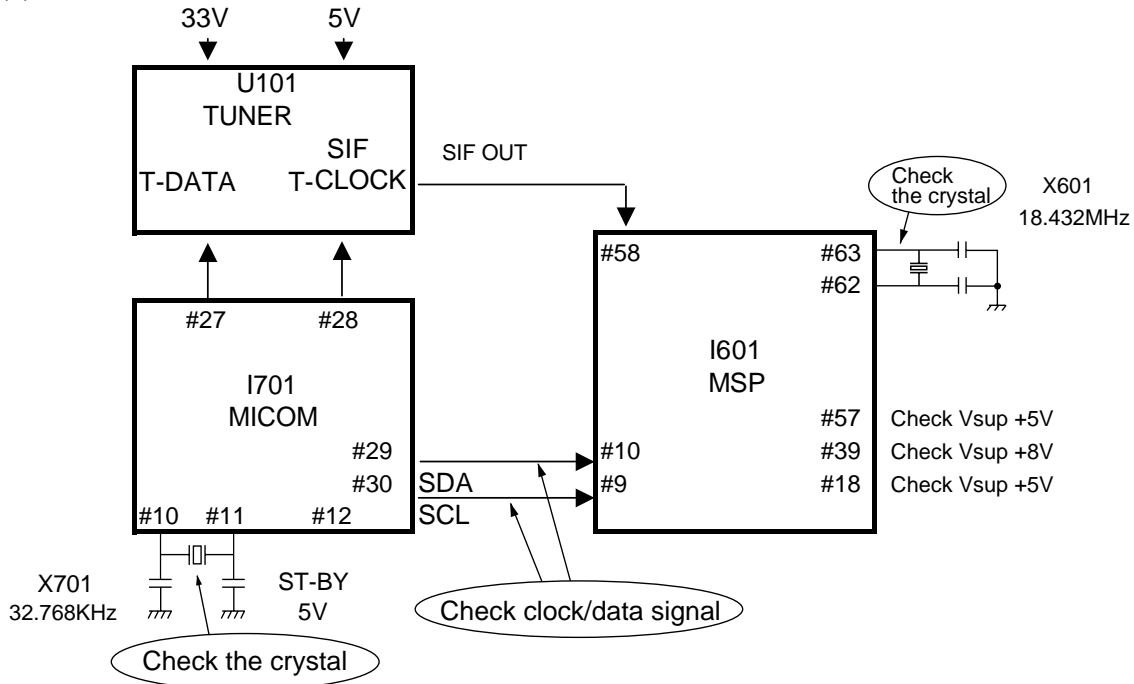

(f)

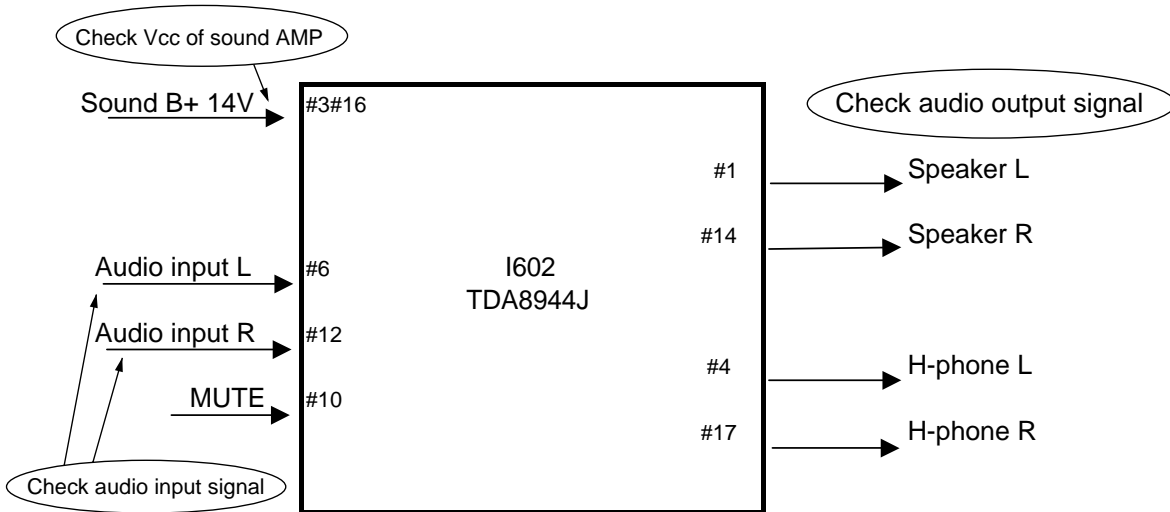

4. CH DON'T MEMORY or SKIP

Check the input signal conditions	NG : Loss of signal or weak signal
	OK : Go to the figure (g)

(g)

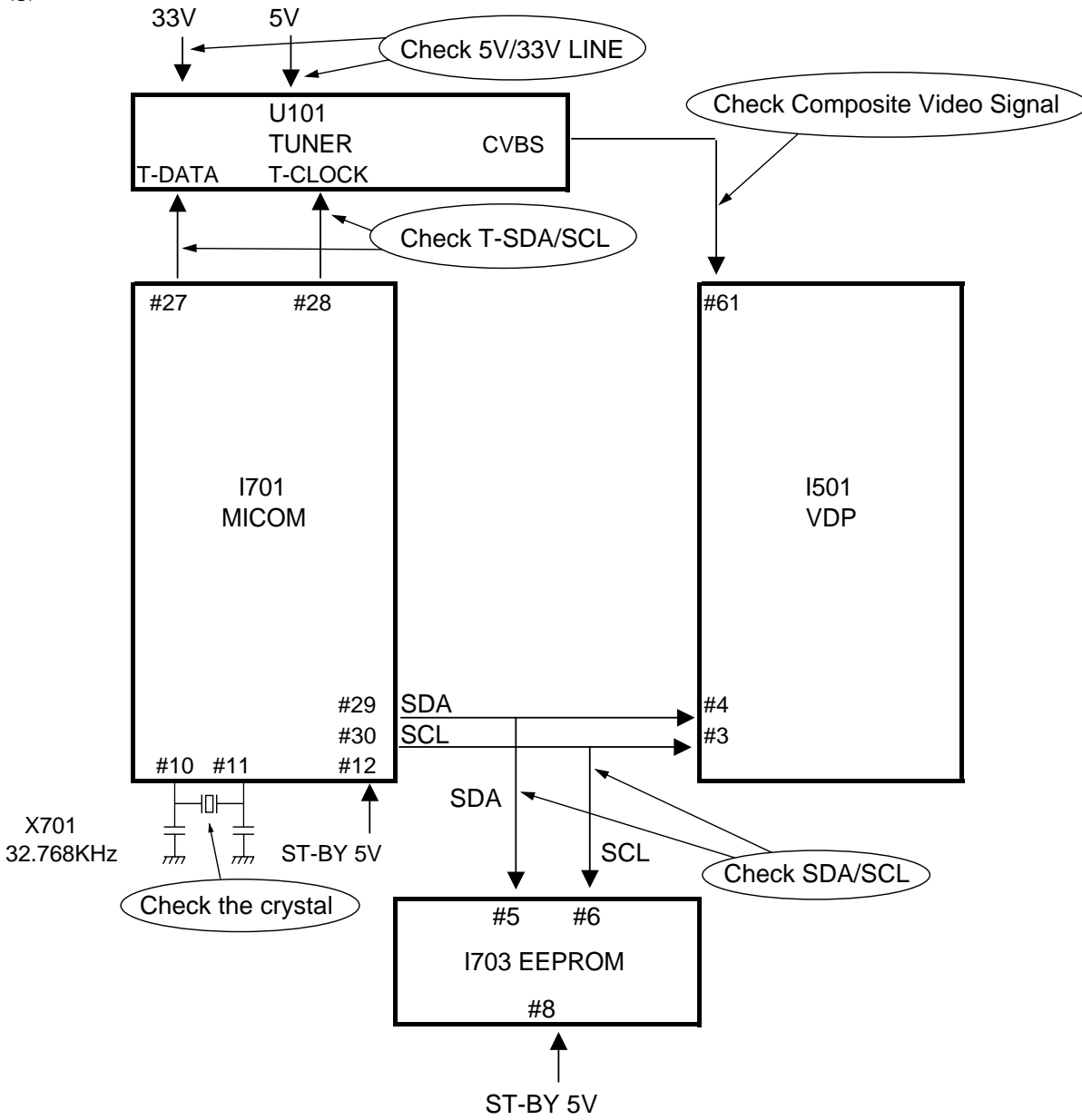

5. NO COLOR

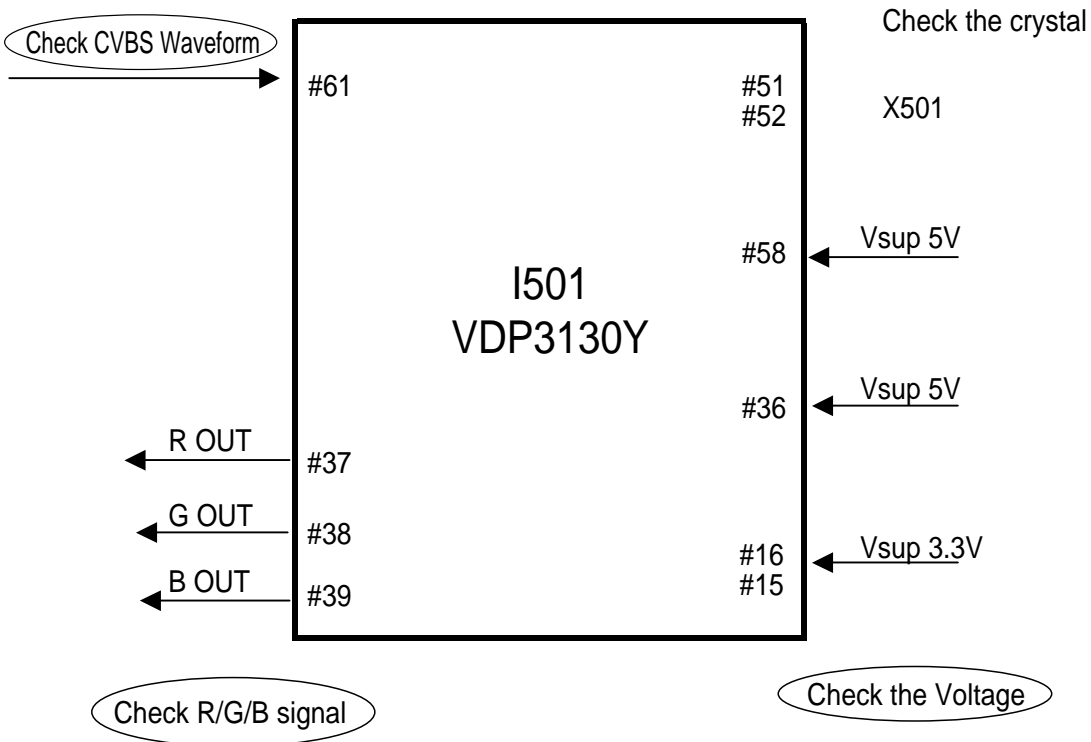

6. NO VERTICAL DEFLECTION

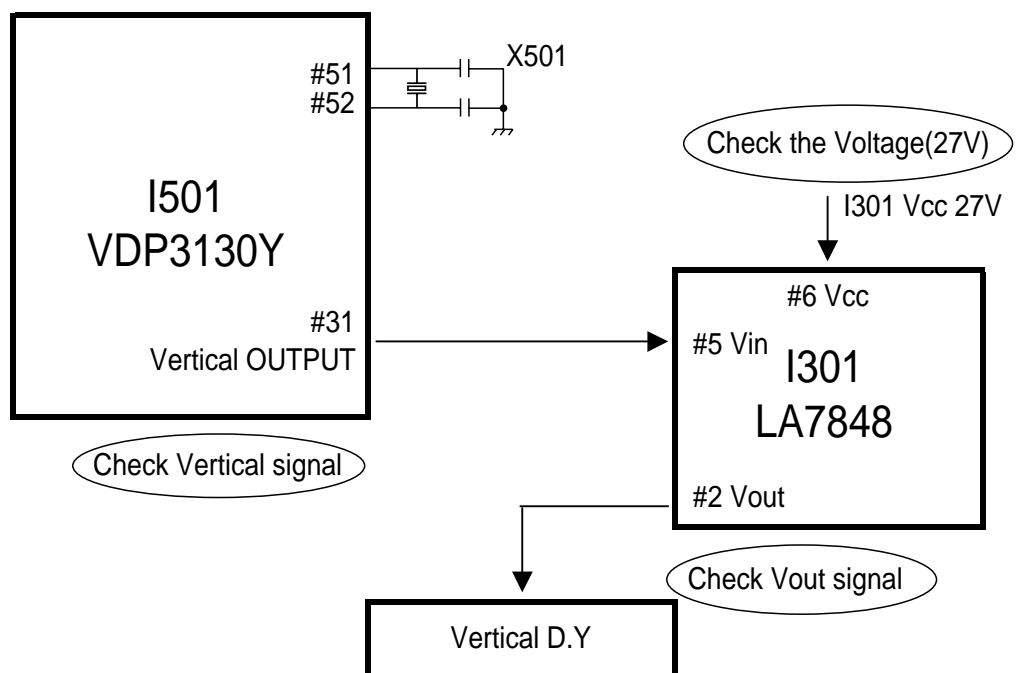

7. NO ON-SCREEN DISPLAY

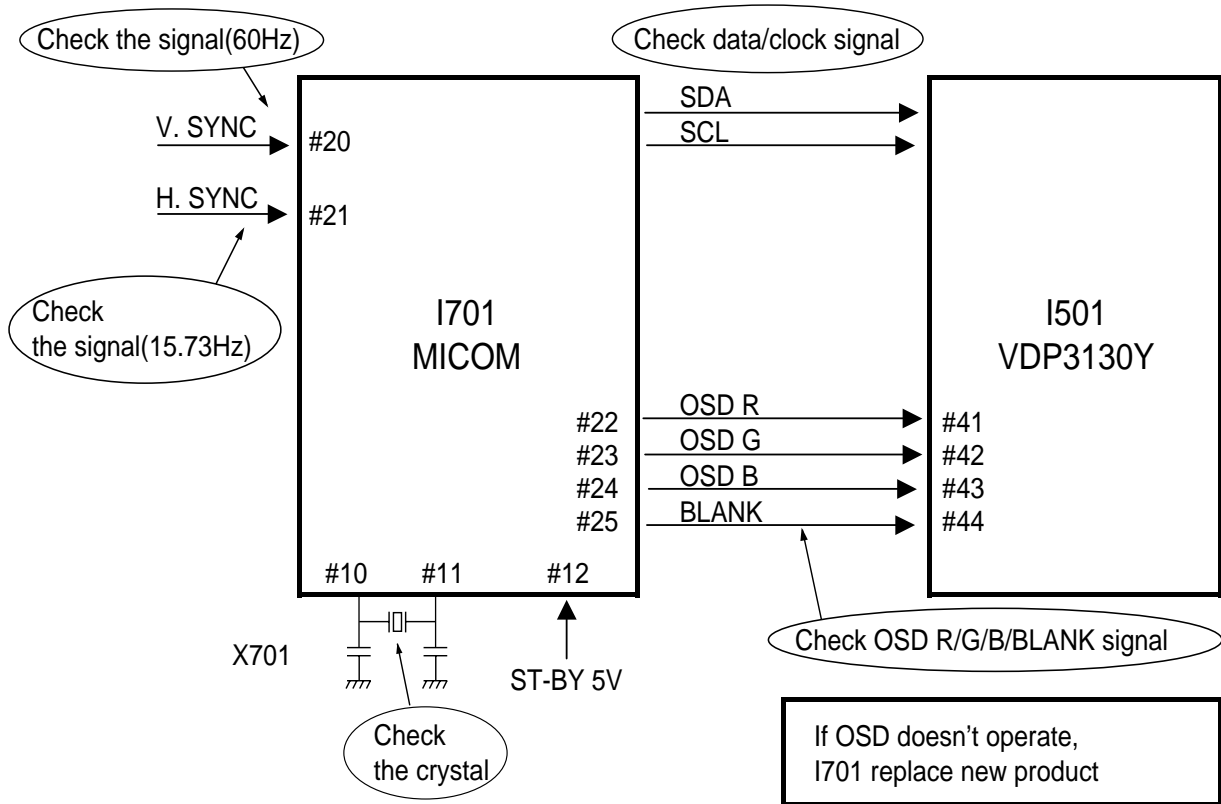

8. REMOTE CONTROL DOES NOT OPERATE

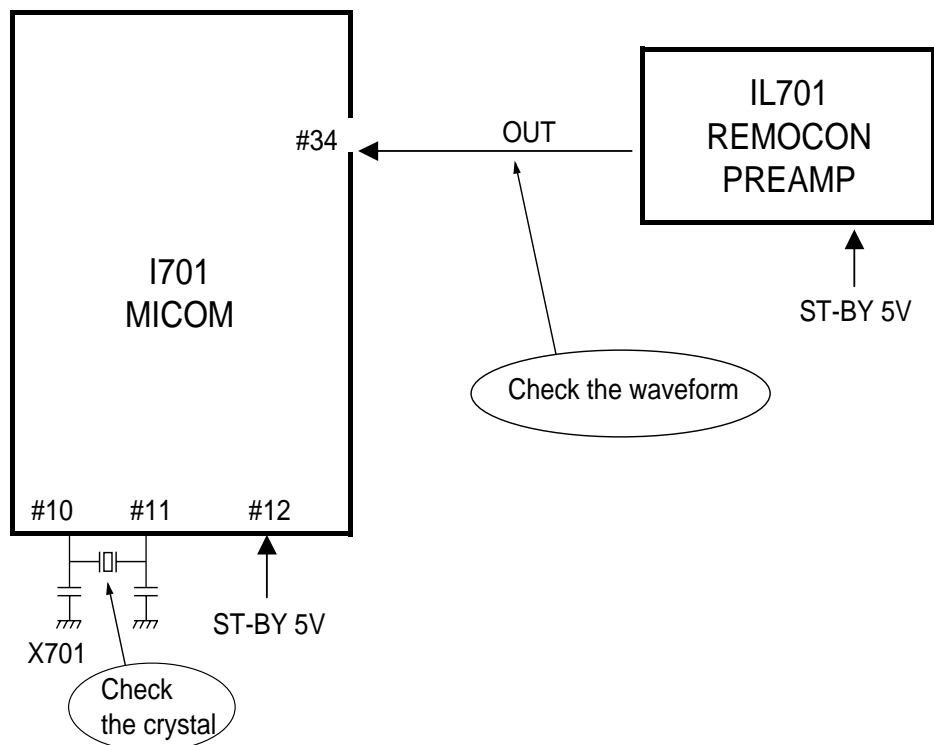

DAEWOO

DAEWOO ELECTRONICS Corp.

686, AHYEON0DONG MAPO-GU

SEOUL, KOREA

C.P.O. BOX 8003 SEOUL, KOREA